

**MESys Solar**

8 Airport Road  
Bethel, Maine 04217

Phone: 207-824-6749  
Fax: 207-824-4816

info@maineenergysystems.com  
MESysSolar.com

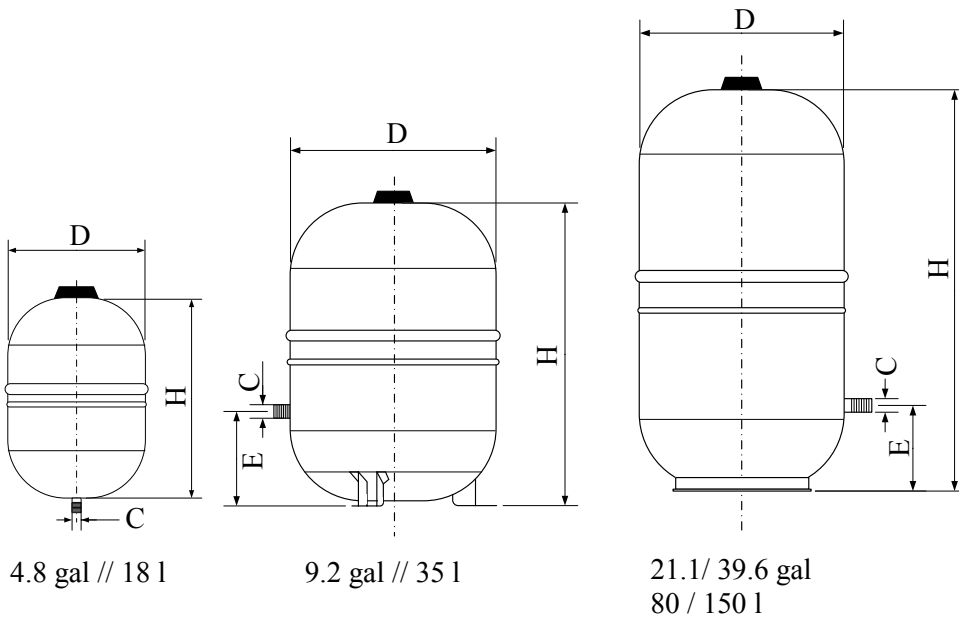

**Dimensions**

	4.8 gal // 18 l	9.2 gal // 35 l	21.1 gal // 80 l	39.6 gal // 150
<b>Diameter D [in]</b>	10 5/8	15	17 3/4	19 3/4
<b>Height H [in]</b>	13 3/4	14 3/8	24	35 1/4
<b>Connection C</b>	3/4" MPT	3/4" MPT	1" MPT	1" MPT
<b>Inlet E [in]</b>	--	5	6	8 1/2
<b>Part No.</b>	<b>08-2138</b>	<b>08-2139</b>	<b>08-2140</b>	<b>08-2076</b>

**Technical Data**

- fixed membrane expansion tank
- for closed hydraulic solar thermal system operated with water or glycol
- shell material: carbon steel
- connection material: carbon steel ;MPT
- membrane material: Butyl rubber
- exterior coating: epoxy-polyester powder coated in white
- max. working pressure: 150 psi // 10 bar
- max. operating temperature: 212°F // 100°C
- factory pre-charge: 36 psi // 2.5 bar

