

Operating Instructions Manual

Janfire NH/Integral Pellets Burner with External Auger



For the homeowner. This operating manual must be kept near the boiler.

Due to constant development, Janfire AB reserves the right to change part or parts of this publication at any time without notice.

Due to constant development, Janfire AB reserves the right to change part or parts of this publication at any time without notice.

Contents

- 1 Safety Instructions 4**
 - 1.1 General 4
 - 1.2 Conventions..... 5
 - 1.3 Safety Instructions for Installation and Service..... 6
 - 1.4 Safety Systems..... 6
 - 1.5 Compliance declaration 7

- 2 Technical Data 8**

- 3 Operational Description.....9**

- 4 Maintenance..... 12**
 - 4.1 Menu System..... 13
 - 4.2 Volume Adjustment 15
 - 4.3 Energy Value 15
 - 4.4 Choice of Input Value 16
 - 4.5 Starting the Burner 16
 - 4.6 Starting the Burner After the Installation..... 17
 - 4.7 Stopping the Burner..... 18
 - 4.8 Pellets Filling 19
 - 4.9 Cleaning 20
 - 4.10 Cleaning the Dosage Auger 21

- 5 Trouble-Shooting..... 22**
 - 5.1 The Burner has Stopped 22
 - 5.2 Yellow Control Lamp; Burner Running 24
 - 5.3 Too low Output from the Burner 25
 - 5.4 Resetting the Automatic Fuse 26
 - 5.5 Adjusting the Capacity Sensor 27

1 Safety Instructions

1.1 General

The following safety instructions are based on risk analysis, which where compiled according to the relevant company measures.

Read the safety instructions carefully before installation. Always follow the safety instructions during installation and during maintenance. Follow the safety instructions on the warning signs!

Installation, operation, service and any other work should be carried out by qualified personnel and in accordance to local standards and regulations.

NOTE Always follow the instructions for installation, operation and service.

NOTE For personal and operational safety: Use only spare parts, which have been manufactured or approved by Janfire AB.

1.2 Conventions

These safety instructions use the following protocols:

- DANGER!

The text “DANGER!” is used when there is a risk for personal injury or death.

- WARNING!

The text WARNING! Is used when there is a risk for damaging the product, unit or control box etc.

- CAUTION!

The text CAUTION! Is used when there is a risk for a system failure, operational stop, or disturbances etc.

The warning texts are in hierarchical order. The text “DANGER!” also includes the possibility of the events covered by “WARNING!” or “CAUTION!”.

1.3 Safety Instructions for Installation and Service

All electrical installation and service should be carried out by qualified personnel and in accordance to local standards and regulations.

All plumbing should be carried out by qualified personnel and in accordance to local standards and regulations.

All decarbonization should be carried out by qualified personnel and in accordance to local standards and regulations.

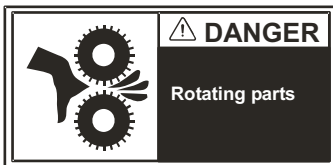

1.4 Safety Systems

The following safety systems are included in the Janfire NH pellet burner:

- A non-combustible drop shaft protects against reverse combustion.
- A temperature sensor in the drop shaft gives a reading which, if exceeds 158°F (70°C) reduces the burner output until the temperature decreases to under 140°F (60°C).
- A flexible tube of special plastic.
The tube between the external screw and the burner is constructed of a special plastic material, which melts (not burns) at high temperatures and breaks the contact between the pellet feeder auger and burner.
- Circuit breaker
The burner is equipped with a micro-switch circuit breaker, which prevents the burner from operating when detached from the boiler.
- Two electrical fuses to protect electrical components from over current draws.
- A 10 Amp resettable fuse is located above burner wiring terminal to protect internal electronics.
- A 15 Amp fast blow fuse protects the ignition heating coil.

NOTE The Janfire NH pellets burner should have ample clearance in accordance to local codes.

1.5 Compliance Declaration

The Janfire NH burner has been tested and is approved for use with the MESys 4000 - 6000 boilers and meets the UL 391-2006 and CAN/CSA B366.1-M91 standards. All electrical components of the Janfire burner are UL approved.

2 Technical Data

Janfire NH Pellet Burner	
Burner input capacity	10,000 - 72,000 Btu/hr (3 - 21 kW)
Maintenance output	2,000 Btu/hr (600 W)
Burner power consumption	80 W, 120 V AC, 60 Hz
Automatic Ignition coil	1100 W
Pellet storage volume	Internal storage: .75 gal (94 lbs) (3 litre = 1.8 kg)
Internal dosage motor	120 VAC , 60 Hz
Combustion fan	Variable speed operation
Self-cleaning burner chamber	120 VAC , 60 Hz
Control panel	Touch-button
Fuses	10A automatic fuse (reset table) 15 Amp fast blow fuse
External auger	1-phase 120 V AC, 60 Hz, 250W, 2.4 A, External auger cannot exceed 14ft (4.30m).
Weight	55 lbs (25 kg)

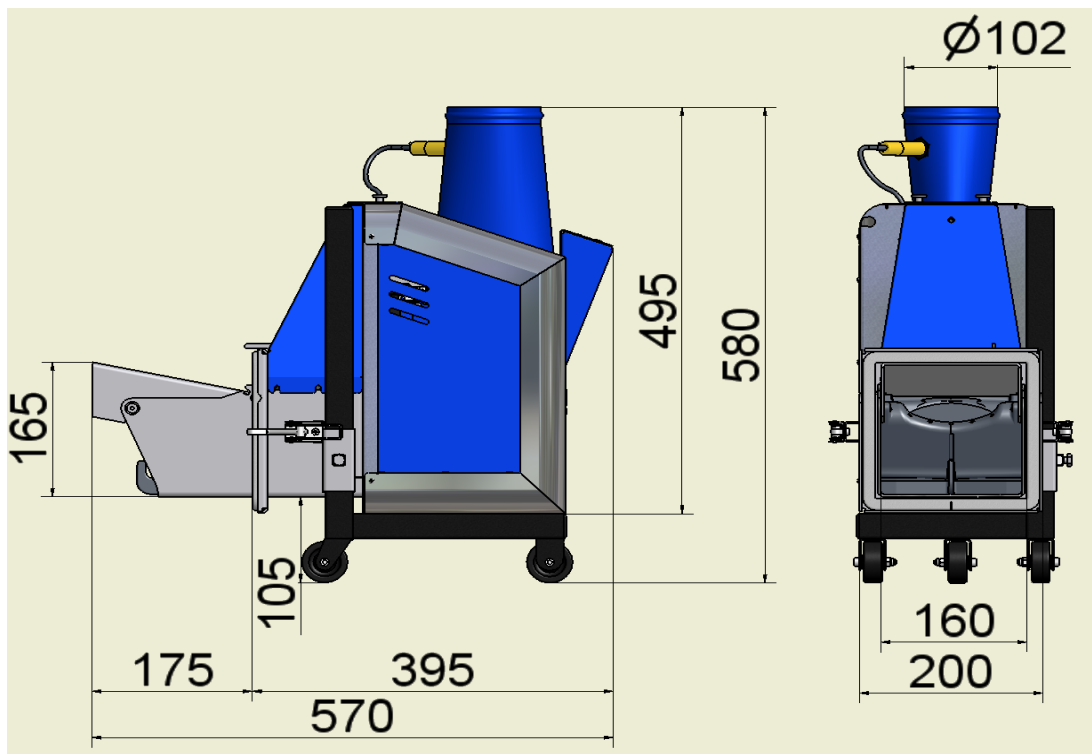

Figure 1. Dimensional drawing NH-burner (all measurements in mm)

3 Operational Description

An external auger feeds pellets from an external storage to a receptacle in the burner (internal storage). An internal dosage auger then feeds the pellets to a drop shaft where they fall freely into the combustion chamber; this eliminates the possibility of reverse combustion.

A fan feeds the burner with primary and secondary air. On its way to the burning cup the air cools heat-exposed parts of the burner. The correct amount of air is then fed into the burning cup for primary and secondary combustion. The ignition coil preheats the air for automatic ignition. The temperature sensor (flame guard) placed inside the burning cup notes when the pellets have ignited by means of a temperature rise. If ignition did not succeed then the burning cup is automatically cleaned and a new attempt is made. If ignition still does not work then the burner is shut down.

If the airflow is insufficient then the hot flue gases will rise into the drop shaft. The drop shaft temperature sensor will register this rise in temperature and the burner will compensate by reducing the output, thus eliminating the risk for reverse combustion. When this takes place the control lamp changes color to yellow to indicate that the system is running in backup level and "reduced output" will appear on the display screen.

If the temperature still rises to the highest allowed level then the burner will shut down with help of the temperature sensor in the drop shaft. The control lamp will turn red and "Error Low Draft" will appear on the display screen.

High quality premium pellets produce high efficiency and output. High quality pellets are solid wood pellets 1/4" - 3/8" (6-10 mm) with little dust. Moisture levels should be no higher than 10%, ash content no higher than 1% weight, and energy content should be about 7,290 to 7,750 Btu/lbs** (4.7 and 5.0 kWh/kg). Make sure you see a content declaration for the pellets on delivery.

**Note: Contact your pellet supplier regarding the dry matter energy value, or European Net Heat Value (ENHV), which is discounted for pellet moisture content as the Janfire NH burner requires this specific value. US PFI (Pellet Fuel Institute) pellet standards at this point do NOT record this value and the PFI energy content value can NOT be used directly.

A patented moving base of the burning chamber scrapes away slag and waste material, feeding it into the boilers firebox. The burner automatically cleans itself according to a signal from the boilers thermostat or from pre-programmed intervals (number of pellet fillings).

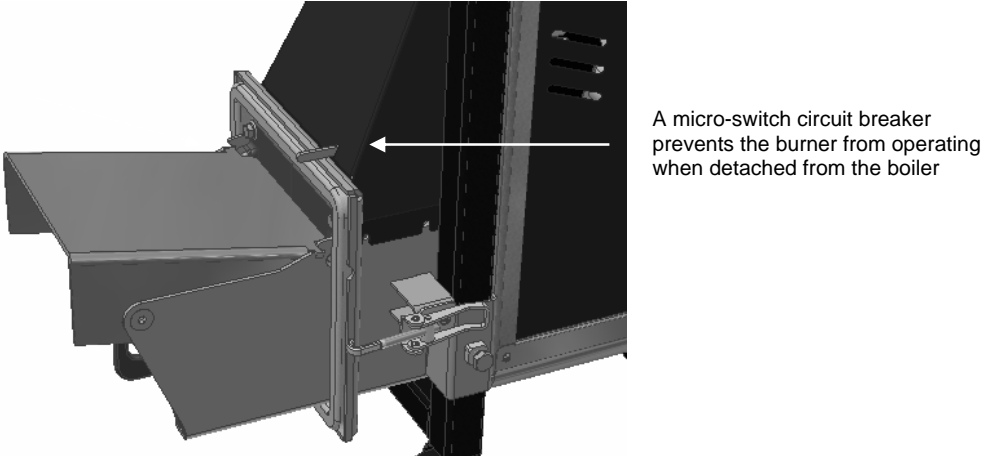

A micro-switch circuit breaker prevents the burner from operating when detached from the boiler

Figure 2 Circuit breaker

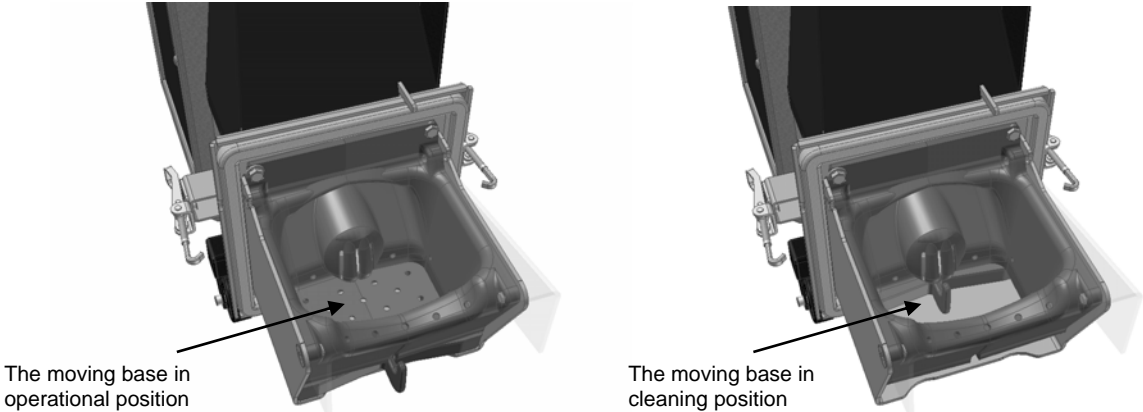

The moving base in operational position

The moving base in cleaning position

Figure 3 Moving base

The moving base of the burning chamber scrapes away slag and waste material, feeding it into the boiler's firebox according to a signal from the boiler's thermostat or from pre-programmed intervals (number of fillings).

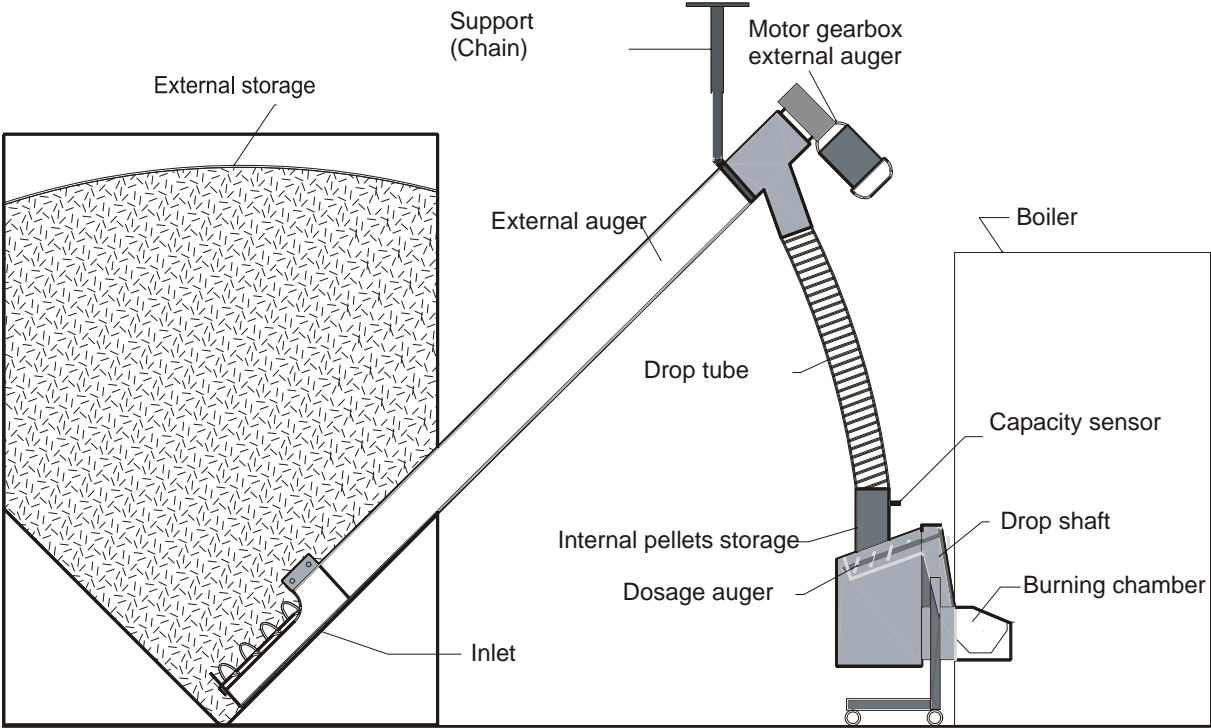

Figure 4. Function description

4 Maintenance

Thanks to a new patented technique the Janfire NH Pellets burner has the least need of maintenance of all pellet burners on the market. When mounted on an existing boiler the ash handling varies depending on the size of the boilers ash container.



For optimal and safe operation it is important that all adjustments of the burner's operational parameters are correct. We recommend that you sign a service agreement with your retailer.

NOTE Regularly check that the gasket around the burner is not damaged.

4.1 Menu System

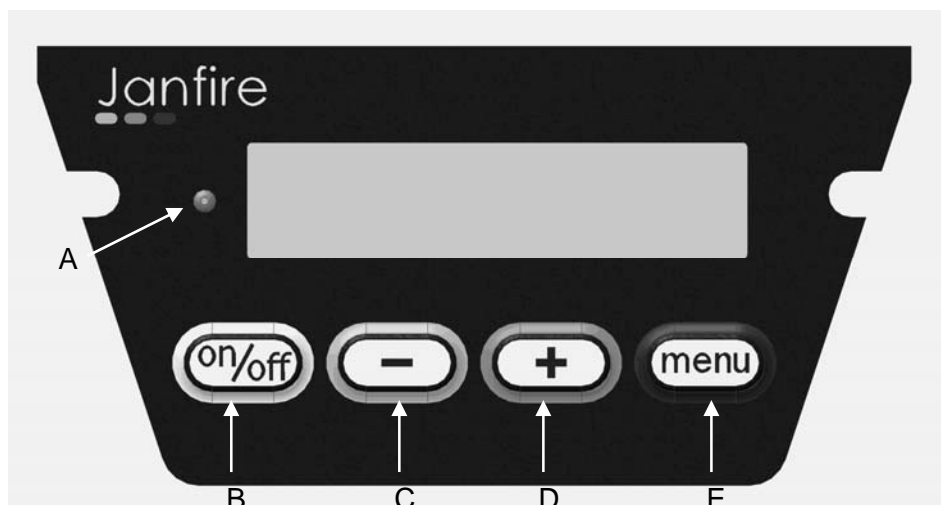

Figure 5 Menu system

Janfire NH Control panel	
A	Control lamp: Green = Normal, Yellow = Warning, Red = Error, Yellow/Red = Manual Stop
B	Start/Stop
C	Reduce value
D	Increase value
E	Scroll menu (quick press). Save/confirm value (press for three seconds)

Menu System for the "Janfire NH"

One press on the "on/off" button stops all activities in the burner. Press again and it continues where it left off.

On start up **status** will be shown in the display. When not pressing any buttons for 5 minutes, the status mode will appear in the display automatically.

Every press of the menu button scrolls through the menu list below.

Adjustments are done using the "-" and "+" buttons and must be saved by pressing and holding the "menu" button for 3 seconds ("save to memory" appears on the display).

Status: This shows the present status information; it can show errors or running status etc.

Pellets used: This shows calculated pellet consumption. One counter is resettable, the other counter indicates total consumption.

Choose output level: Here you can choose different maximum output levels.

Ash scraping: Every 40 lbs. of pellets used (range adjustable from 3 - 100 lbs/scraping).

Volume settings: The correct level must be supplied by your pellets supplier or by weighing.

Energy level: Your pellets supplier must supply the correct level.

Automatic start after Power Failure: Choose if the burner should automatically start when the power is turned on. This function should always be “on” if the burner can start after a power cut.

Running down: Is used when you wish to remove the ash from the boiler. Running down function runs in three sequences, begin cooling, burning cup scraping and then combustion stop. Pressing the “menu” button for more than 3 seconds activates this.

NOTE This function is shown only when the burner is running.

Manual dosage feeding: Press and hold down the “+” button and the dosage auger will run until the button is released.

NOTE This function is shown only when the burner is stopped.

Manual external auger: Press and hold down the “+” button and the dosage auger will run until the button is released or when the level meter in the filling tube is effected.

NOTE This function is shown only when the burner is stopped.

4.2 Volume Adjustment

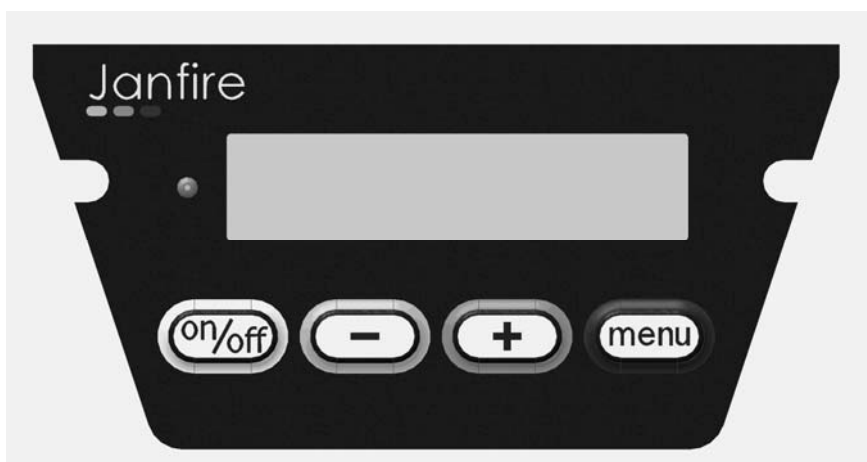

To achieve the best combustion and least exhaust a correct level for the volume weight of the pellets is needed. The correct level can be supplied by your pellets supplier or by weighing.

5.77lbs./gal (42.18 lbs/ft³) (675 g/l) is the standard level, which is the average weight per liter pellets.

When adjusting the levels the dosage time is also changed (normally 1 sec.) to compensate for any discrepancies and to ensure good combustion.

To change: Scroll in the menu until you come to "volume weight xxx lbs/ft³" and change with "-" and "+". To save the new level by pressing and holding down the "menu" button for 3 seconds.

Weighing: Fill a 5 gallon container with pellets and weight it on a scale. Make sure to subtract the empty weight of the container. Compute net weight per gal by dividing by 5. Record net weight in lbs. Multiply now by 7.31 to get lbs/ft³ and program whis value into the NH burner.

4.3 Energy Value

To achieve good combustion and reduced exhaust gasses, the correct energy density value for the pellets is required and must be inputted into the burner. Your pellet supplier can supply this information.

The European Net Heat Value (ENHV) for a pound of pellets at 100% dry mater is expressed as 7.745 Btu/lbs (4.80 kWh/kg). Always check with your pellet supplier regarding its ENHV value! When this value is changed in the burner controller, the dosage auger feeding time is also changed (normally 1 sec.) to compensate for any deviations in the energy density value and to ensure good combustion.

To change the energy density value: press the menu button repeatedly until "Energy density xxx Btu/lbs" is shown and change its value by pressing the "-" or "+" buttons.

To save the energy density value: Press and hold down the "menu" button for 3 seconds.

4.4 Choice of Input Value

Press and scroll through the “menu” button until you come to “Select Power Level xx MBTU”. By pressing “+” or “-“ buttons you can choose between the maximum input level. The setting specifies the maximum input level during modulating operation. To save the new level; press and hold down the “menu” button for 3 seconds.

4.5 Starting the Burner

1. Roll the burner into the boiler and lock it in place on both sides.



NOTE The burner should be fitted securely so that no embers or smoke are released. A non-airtight connection can lead to poor combustion and function.

2. Check that there are sufficient pellets in the external storage. The pellet level should not be lower than the external auger's inlet.
3. Check that the power cables between the burner and boiler and between the boiler and the external auger are connected. Verify that the drop tube between the external motor and the burner is secure.
4. Switch on main power.

NOTE The main power switch is usually located on the wall next to the boiler or by the entrance to the boiler room.

5. Switch on the power to the burner (the switch is on the boiler) and the boiler will start automatically at the 37 MBTU (12 kW) input level (Auto start at restart).
6. The change to the desired input level: Scroll the “menu” button until you come to “Select output xx MBTU”. Change the value by pressing the “+” and “-“ buttons. Save the new level by pressing and holding down the “menu” button for 3 seconds, “Saved to memory” will appear on the display screen.
7. To achieve a good combustion with low exhaust the values of the pellet's volume weight and energy value has to be correct. The correct level can be supplied by your pellet supplier or by weighing. To change; scroll the “menu” button and change the value by pressing the “+” and “-“ buttons. Save the new value by pressing and holding down the “menu” button for 3 seconds.

If the burner is calling for heat and the internal storage is filled, the burning cup is then cleaned. The start sequence then begins. Pellets are fed in, the ignition spiral warms up and the fan starts. The start sequence is pre-programmed to deliver a fast ignition and exhaust levels as low as possible. The start up runs for about 10 minutes after which the chosen input level begins.

4.6 Starting the Burner After the Installation

NOTE It is important that when starting up for the first time that the internal storage and the dosage auger are full with pellets.

1. Switch on the power to the burner. After 2 minutes the external auger starts. The feeding stops after 2 minutes or sooner. If the internal storage is not filled within 2 minutes press the "ON/OFF" button and the auger will continue to feed. Continue this process until the correct level is reached. When the internal storage is full a sensor stops the external auger.

The external auger can be operated manually: Scroll the menu until you come to "manual external auger", then press and hold the "+" button to start the motor. Fill until the burner's internal storage is full. The motor will stop when the "+" button is released or when the internal storage sensor is activated. Since the automatic system will normally "Auto start at restart" and will try to continue press the "ON/OFF" button to stop the burner. "Stopped manually" will appear on the display screen. Manual pellet feeding is only possible when the system is off.

2. Since the internal storage has been filled the internal feeding auger must also be filled. This can be done manually by scrolling the "menu" button until you come to "Manual feeding", then press and hold the "+" button to start the motor, let it run until pellets start to fall into the burning cup. The motor will stop when the "+" button is released.
3. Press the "ON/OFF" button to start the burner

The output level without maintenance should be chosen during the summer or with minor need of heating around the year due to the fact that the burner shuts down when the water temperature has been reached. The burner will automatically turn itself on when needed.

The output level with maintenance should be chosen during the winter or when a greater need or when the thermostats stop is short (20-30 min.). The burner returns to standby after it has reached the required temperature max. 1 hour (factory setting). In standby the burner runs on a very low output (2000 Btus) (0.6 kW) that keeps combustion ready for a quick output increase when signalled by the thermostat. Should the thermostat take more than 1 hour to signal then the standby setting is stopped and the burner reverts to standby and will start when needed.

4.7 Stopping the Burner

The burner can be stopped in the following ways:

- **Press the “ON/OFF” button to stop the burner”**
“Stopped manually” will appear on the display screen. All of the burner functions will stop. This is standby. “Stopped manually” is shown in the display and the control lamp turns red. This will ensure that the burner will not start accidentally at a power failure. Pressing the "ON/OFF" button again restarts the burner at the point when it was stopped. (It can continue in stand by mode or cool down, scrape clean and begin a new start up depending on how long it was turned off). Switch off the main power if you wish the burner to remain shut down.
- **”Shut down”in the menu**
When it is time to remove the ash the burner should be cooled and scraped. This function is only activated when the burner is running by scrolling through the menu until you come to “Shut down”. Press and hold down the “Menu” button for 3 seconds to activate. This can take up to 10 minutes depending on the program chosen. “Manually stopped” will appear on the display screen and the control lamp will turn red. Switch off the main power if you wish the burner to remain shut down.
- Turn off main power for the burner to remain shut down. "Manually stopped" is shown in the display and the control lamp turns red. This will ensure that the burner will not start accidentally after a power outage.

NOTE Do not switch off the main power until the fan has stopped.

NOTE Always switch off the power at the main power switch when the burner is to be off for a longer period or when servicing the burner. The main power switch is usually located on the wall next to the boiler or by the entrance to the boiler room.

4.8 Pellet Filling

The external auger can only feed the pellets to the burner if the external storage level is above the external augers inlet.

NOTE Add pellets to the external storage when needed.

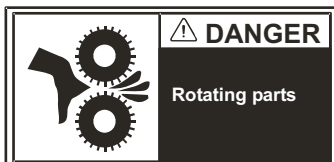

NOTE Do not touch the dosage auger or the external augers in or outlet when the external motor is connected.

4.9 Cleaning

1. Stop the burner according to the instructions in chapter 4.7.
2. Wait for 30 minutes until all glowing pellets have burnt out.
3. Disconnect the burner and roll it away from the boiler.



NOTE The burner and the burning chamber can still be hot and the cinders still be glowing.

4. Lift the flame deflector cover out with a pair of insulated pliers or wear protective gloves.
5. Clean the plate and the burning chamber carefully. Use a vacuum cleaner together with the Janfire ash container (accessory).

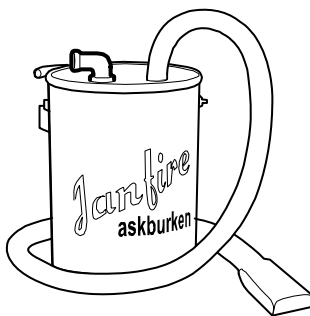

6. Pour 1/2 cup of water on the burning plate on the bottom of the burning bowl. The water will loosen and dissolve any slag.
7. Put the plate back in place.



NOTE The flame deflector cover must be put back and rest securely on top of the burning chamber.

8. Remove ash from the boiler. Open all doors to reach all convection areas and flue gas pipes.

NOTE Do not forget to clean around the smoke pipe so that no ash prevents the smoke to reach the chimney.

4.10 Cleaning the Dosage Auger

1. Stop the burner according to the instructions in Chapter 4.7.

NOTE The main power switch is usually located on the wall next to the boiler or by the entrance to the boiler room.

2. Remove the lid from the drop shaft and clean the dosage auger with a screwdriver if necessary to remove stuck pellets.

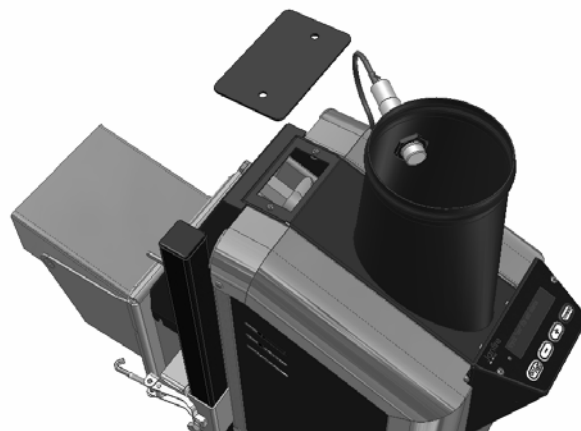
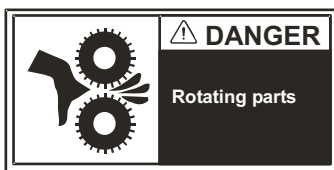

NOTE Do not touch the dosage auger or the external augers in or outlet when the external motor is operational.

3. Switch on the main power.
4. Press the "on/off" button to stop the burner.
5. Start feeding away pellet remainders by pressing the "menu" button until you reach "Manual feeding" in the menu and press the "+" button to start the motor. Continue feeding until you see good quality pellets in the auger.

5 Trouble-Shooting

5.1 The Burner has Stopped

Event	Probable cause	Action
The green lamp on the control panel has gone out and the burner has no voltage.	The fuse has blown.	Reset the fuse (see chapter 5.4). The burner will start automatically. Should the fuse blow again contact your MESys trained service technician.
	The High Limit for the boiler has been opened.	Wait for the boiler to cool. Operate pump to dissipate the heat.
The control lamp shows red "!!! ERROR !!! low draft"	Poor chimney performance/ash build up.	Check the draft. Turn off the main switch Clean the boiler and flue pipes according to instructions. Inspect and clean the chimney.
The feeding of the external auger has stopped. The control lamp shows red "!!! ERROR !!! External"	The external storage is empty.	Fill the external storage with pellets.
	The drop tube is stuck with pellets. The level of the capacity sensor has been altered.	Adjust the capacity sensor
	The drop tube between the external auger's outlet and the burner's inlet has come loose.	Mount the drop tube and start the burner according to instructions.
	Strange objects in the auger (gravel, cloth etc) which prevents the auger from rotating.	Knock carefully on the auger with a rubber/plastic hammer while you run the motor manually until the object comes loose and the auger rotates correctly again. Should this not work the auger may have to be dismantled. Contact your MESys trained service technician.
	Hollowing or crater in the external pellets storage.	Level the pellets in the external storage.
	The pellets get stuck in the tube and do not reach the burner. The tube between the external auger and the burner is too loose or the tube angle is insufficient.	Check if the pellets are stuck at the external auger's outlet. Clean if necessary. Stretch the tube, straighten the angle of the tube.

Event	Probable cause	Action
Control lamp turns red "!!! ERROR !!! burner disconnected"	The burner has been disconnected from the boiler	Connect the burner to the boiler. Press "ON/OFF" to start.
	Faulty circuit breaker or incorrectly adjusted circuit breaker.	Adjust or replace. Contact your MESys trained service technician for assistance.
Ash scraper is stuck "!!! ERROR !!! ash scraper"	The ash in the burning chamber sinters to hard slag. Insufficient pellet quality.	Remove the slag from the burning chamber. Lower the amount of feedings for ash scraping. Press "ON/OFF" to start
	Ignition is not working. Pellets may be stuck between the scraper and the burning chamber	Remove pieces of pellets from the burning chamber. Press "ON/OFF" to start If this problem occurs again contact your MESys trained service technician.
Flame guard has been activated: The control lamp turns red. "!!! ERROR !!! Ignition"	Ignition has not occurred or a faulty ignition coil.	The level of pellet in the burning chamber is too low. Check that pellets are fed to the dosage auger before the start. Contact your MESys retailer or a service technician to replace the ignition coil. Check the 15A fuse as it protects the ignition coil from over current. Replace with a 15A fast blow fuse.
	Bad quality pellet.	Change to better quality pellet.
	Insufficient draft in the boiler can cause disturbance in augers due to tar (sticky). This will make the dosage auger stop.	Check values for the boiler's draft. (carried out by MESys trained service technician).
	Strange objects in the pellets or damp pellets causing the dosage auger to stop .	Remove the damp pellets or the strange object .
	The fan is not correctly adjusted.	Contact your MESys trained service technician.
The control lamp turns red "!!! ERROR !!! Fan"	The fan is faulty. Mechanical obstacle that prevents the fan from operating.	Contact your MESys trained service technician.

5.2 Yellow Control Lamp; Burner Running

Event	Probable cause	Action
<p>Control lamp turns yellow The burner still running. The display shows: "reduced output" or "running"</p>	<p>Insufficient draft or ash or soot between the boiler and smoke pipe or foreign objects in the chimney that prevents the smoke from getting out.</p> <p>The lamp indicates that the burner is trying to compensate ("reduced effect" in the display) or has tried to compensate insufficient draft by reducing the effect.</p> <p>The lamp will remain yellow until the burner has been restarted to indicate that there has been a problem with insufficient draft.</p>	<p>Turn off the main switch. Clean the boiler and the flue pipes according to instructions. Inspect and clean the chimney. If necessary check the draft.</p>

5.3 Too low Output from the Burner

Event	Probable cause	Action
The burner does not create enough output.	The chosen output level is too low.	Increase the level of output (see chapter 4.4).
	Insufficient pellets quality.	Contact your pellets distributor and demand a quality declaration. Adjust the volume (see chapter 4.2).
	Too high or too low draft in the boiler.	Check by holding a match in front of a small opening on the boiler (for instance open door slightly). The flame shall lean towards the boiler but not burn out. Contact your MESys trained service technician if you are uncertain.
	The adjusted values for the boiler or the burner are not correct.	Check the protocol from the installation and contact your MESys trained service technician.

5.4 Resetting the Automatic Fuse

If the fuse has blown the red button comes out.
The fuse is reset by pressing the red button.

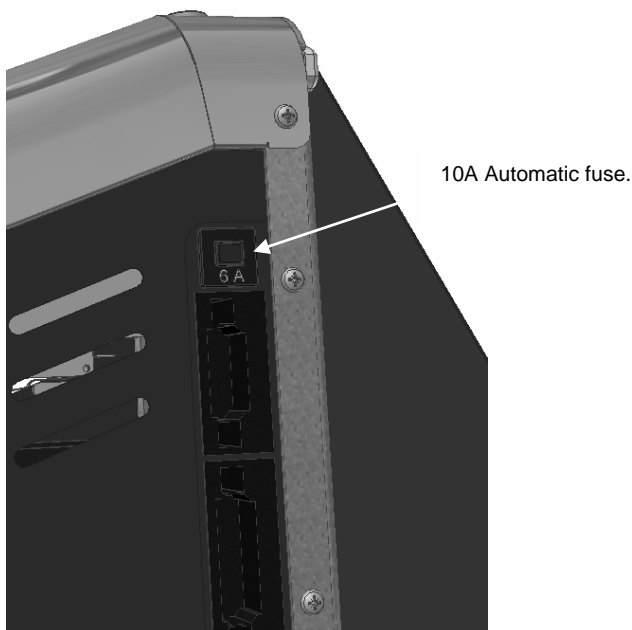

Figure 6 Automatic fuse

The secondary "BUS" fuse is located well below the 10A resettable fuse. This 15A fast-blow fuse which protects the ignition coil and must be replaced when blown.

5.5 Adjusting the Capacity Sensor

The capacity sensor on the burner is pre-set. The setting may alter during transportation or after some time (two weeks) during operation and will have to be adjusted.

1. Stop the burner. The main switch must be left on so that the burner has voltage.
2. Remove the drop tube from the burner's inlet.
3. Check the diode with your finger. The sensor should be lit at a distance of 3/8" (8-9 mm) (see figure below).
4. Use a small screwdriver to remove the protective plug. Turn the adjustable screw until you get the correct distance 3/8" (8-9 mm).
Counter-clockwise means less sensitivity, i.e. reacting at a shorter distance.
Clockwise means higher sensitivity, i.e. reacting at a longer distance.

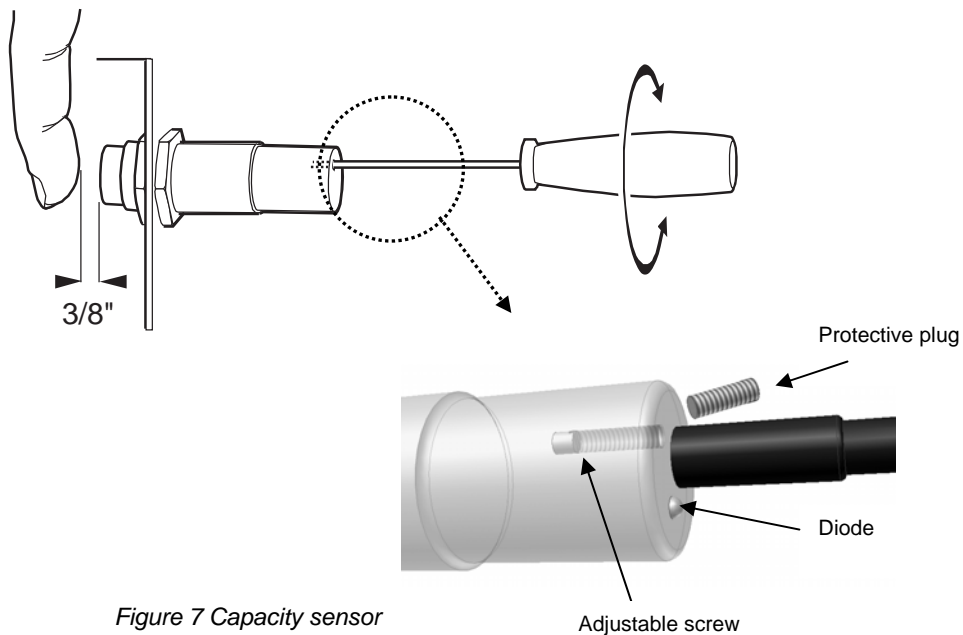

Figure 7 Capacity sensor

NOTE The adjustable screw is very sensitive, only a few degrees are necessary. Do not screw to tight.

5. Mount the drop tube.

Maine Energy Systems, LLC
One Parkway, P.O. Box 547
Bethel, ME 04217-0547
Phone: 207.824.NRGY (6749)
www.maineenergysystems.com

Products Manufactured by:
Janfire AB
Slättertorgsgatan 3,
Box 194,
662 24 Åmål
Sweden

Maine Energy Systems, LLC reserves
The right to make changes without notice
Due to continuing engineering and
technological advances.