

Operating

Instructions Manual



Pelletronic Plus Heating Controller

Version 2.21

**Please read carefully prior to
installation and servicing**

Save these instructions!



MAINE ECO PELLET HEATING LLC

Title: Operating Instructions Manual V 2.01
Item number: USA

Number of version: 01.01
Version valid from: 08/2009
Release: Stefan Ortner

Author:

Maine Eco Pellet Heating LLC

8 Airport Road
Bethel, Maine 04217

USA

office@me-pelletheating.com

www.meco-pelletheating.com

Dear customer!

We are delighted that you have decided to purchase an MEco Pelletronic heating controller.

The Pelletronic heating controller is a high quality product manufactured to the latest technical standards.

- These operating instructions form an easy guide to the most economical and effective use of the Pelletronic heating controller.
- Please read this operating instruction carefully and note the safety warnings.
- Keep all documentation supplied with this unit in a safe place for future reference.
- Please contact your authorised Meco dealer if you have any questions.



Subject to latest technical updates

Maine Eco Pellet Heating LLC reserves the right to make changes to the system.

CONTENTS

A. SAFETY WARNINGS	6
1. TYPES OF SAFETY WARNINGS	6
B. COMPLIANCE AND CERTIFICATION	7
1. INTENDED USE	7
2. IMPROPER USE	7
3. EU STANDARDS	7
C. HEATING CONTROLLER	8
D. USER CONTROLS AND FUNCTION	9
1. USER CONTROL	9
2. FUNCTION	9
3. FLUE GAS TEST MODE – CHIMNEY SWEEP CONTROL	9
E. MENU STRUCTURE	10
F. MENU GUIDE	11
1. MAIN MENU	11
2. MASTER OPERATING MODE	11
3. OUTSIDE TEMPERATURE	11
4. HEATING CIRCUIT	12
4.1. HEATING CIRCUIT TIME PROGRAMME	12
4.2. PARTY FUNCTION	13
4.3. VACATION FUNCTION	14
4.4. HEATING CURVE SETTINGS	14
4.5. SCREED PROGRAMME	17
5. DOMESTIC HOT WATER (DHW)	19
5.1. DHW TIME PROGRAMME	19
5.2. SENSOR ALLOCATION (COMBINATION TANKS ONLY)	20
5.3. DHW RETURN PUMP	20
6. ACCUMULATOR	20
7. SOLAR	21
7.1. SOLAR SUBMENU	21
7.2. SOLAR ENERGY	22
7.3. BOILER DELAY	23
8. PELLEMATIC	23
9. ÖKOMATIC	24
11. EXISTING BOILER	25
12. GENERAL	26

12.1. LANGUAGES	26
12.2. DATE/TIME.....	26
12.3. CONTRAST/BRIGHTNESS	26
12.4. MEASURING VALUES	26
12.5. OUTPUTS	26
12.6. SAVING USER PARAMETERS.....	26
12.7. REMOTE SERVICING.....	27
13. CODE INPUT.....	27
G. START UP	28
1. LEARNING PERIPHERY	28
2. ÖKOMATIC	30
3. RETURN TEMPERATURE INCREASE.....	30
4. EXISTING BOILER.....	31
5. SENSOR CALIBRATION	32
6. ROOM THERMOSTAT	33
7. HEATING CIRCUITS SETTINGS	33
8. DOMESTIC HOT WATER SETTINGS	35
9. RETURN PUMP SETTINGS.....	36
10. ACCUMULATOR SETTINGS	37
11. SOLAR SETTINGS	37
12. SOLAR ENERGY	41
13. SWH BOILER DELAY	42
14. HEAT MAIN CIRCULATION	42
15. PELLEMATIC CMP.....	42
16. PELLEMATIC SETTINGS.....	43
16.1 FROST PROTECTION	44
16.2 CASCADE FUNCTION.....	44
17. GENERAL MENU	51
18. USB	51
H. DIAGRAM OF THE ELECTRICAL CONNECTION	53
I. TERMS OF GUARANTEE.....	59

A. SAFETY WARNINGS

1. Types of safety warnings

There are 4 categories of safety warnings:

1. Danger

	 DANGER
	<p>Failure to observe Danger warnings may result in injury or endanger life.</p>

2. Warning

	 WARNING
	<p>Failure to observe Warning warnings may result in personal injury.</p>

3. Caution

	 CAUTION
	<p>Failure to observe Caution warnings may result in injury and/or damage property</p>

4. Notice

NOTICE
<p>Observation to Notice warnings will help ensure trouble free operation of your Pelletronic Heating Controller.</p>

B. Compliance and certification

1. Intended use

The controller is for use in conjunction with a hydraulic circuit in accordance with the manufacturer's specifications.

The device is not be used for any other purpose.

2. Improper use

	 CAUTION
	Improper use such as changes to default settings in code level by non qualified personnel invalidates the guarantee
	 CAUTION
	The producer accepts no liability for damage to persons or property resulting from failure to observe the operating instructions.
	 CAUTION
	For property damage, because you did not follow the operating instructions, the producer will not assume liability.
	 CAUTION
	Only qualified personnel are permitted to open control units or work on electrical appliances.

3. EU standards



The heating controller is a modern electronic device.

This device uses the latest technology and complies with applicable safety regulations.
The controller complies with the following EU guidelines:

73/23/EWG „Low Voltage Guidelines“

89/336/EWG „EMC Guidelines“, including amendment guideline 92/31/EWG

C. HEATING CONTROLLER

The heating controller is installed in the control board of the Pellematic Boiler

Heating controller



The most important information is displayed in the opening window

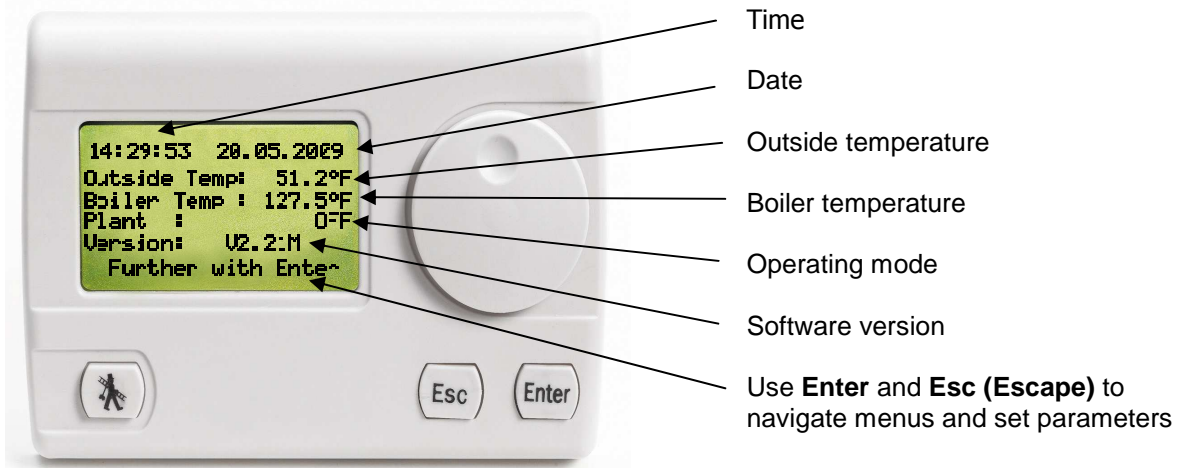

D. User controls and function

Pelletronic functions and displays are controlled using the **MENU SCROLL**, **ENTER** and **ESCAPE** buttons.

1. User control

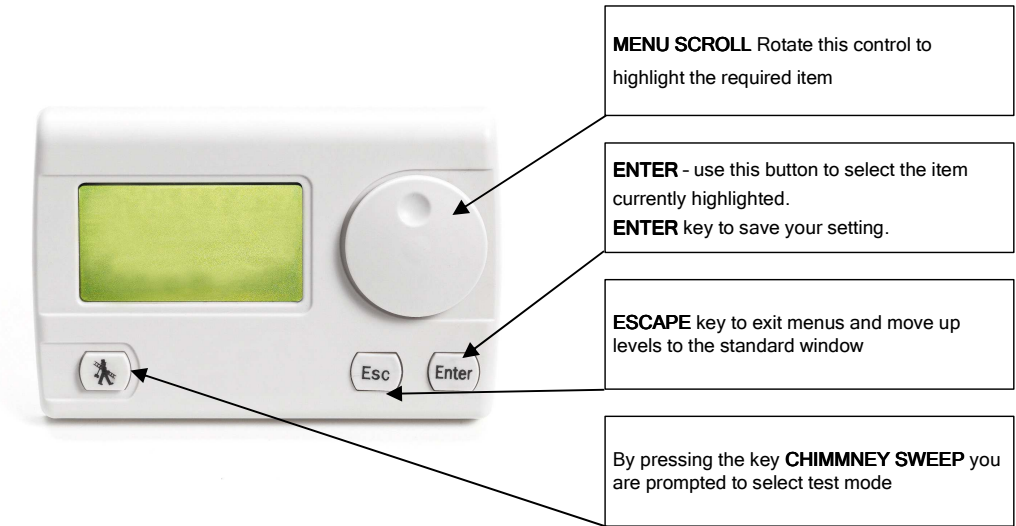

2. Function

```
Heat Circuit 01
Operat Mode: OFF
Set Room Temp: ^^^^^^°F
Set Back Temp: 64.4°F
-----
further | menu
```

1. MENU SCROLL: rotate for desired item
2. ENTER to select item

```
Heat Circuit 01
Operat Mode: OFF
Set Room Temp: ^^^^^^°F
Set Back Temp: 64.4°F
-----
further | menu
```

3. MENU SCROLL: rotate for desired setting
4. ENTER to save settings

```
Heat Circuit 01
Operat Mode: OFF
Set Room Temp: ^^^^^^°F
Set Back Temp: 64.4°F
-----
further | menu
```

5. Use ESC to return to the previous window
6. ENTER to select main menu

3. Flue gas test mode – chimney sweep control

Select flue test mode by pressing the **chimney sweep** (not fitted to wall mounted master controllers)

```
Chimney Sweep
Shall the function
Chimney Sweep
really be
implemented?
-----
yes no
```

To proceed confirm with **yes**.

```
Chimney Sweep
The function
is implemented ...
Boiler Temp: 127.5°F
Final Time : 30 min
-----
Break Off
```

The chimney sweep function sets the boiler to 158°F and allows up to 30 minutes of continuous output for flue gas testing.

E. MENU STRUCTURE

The menu structure shows the menu levels and their functions:

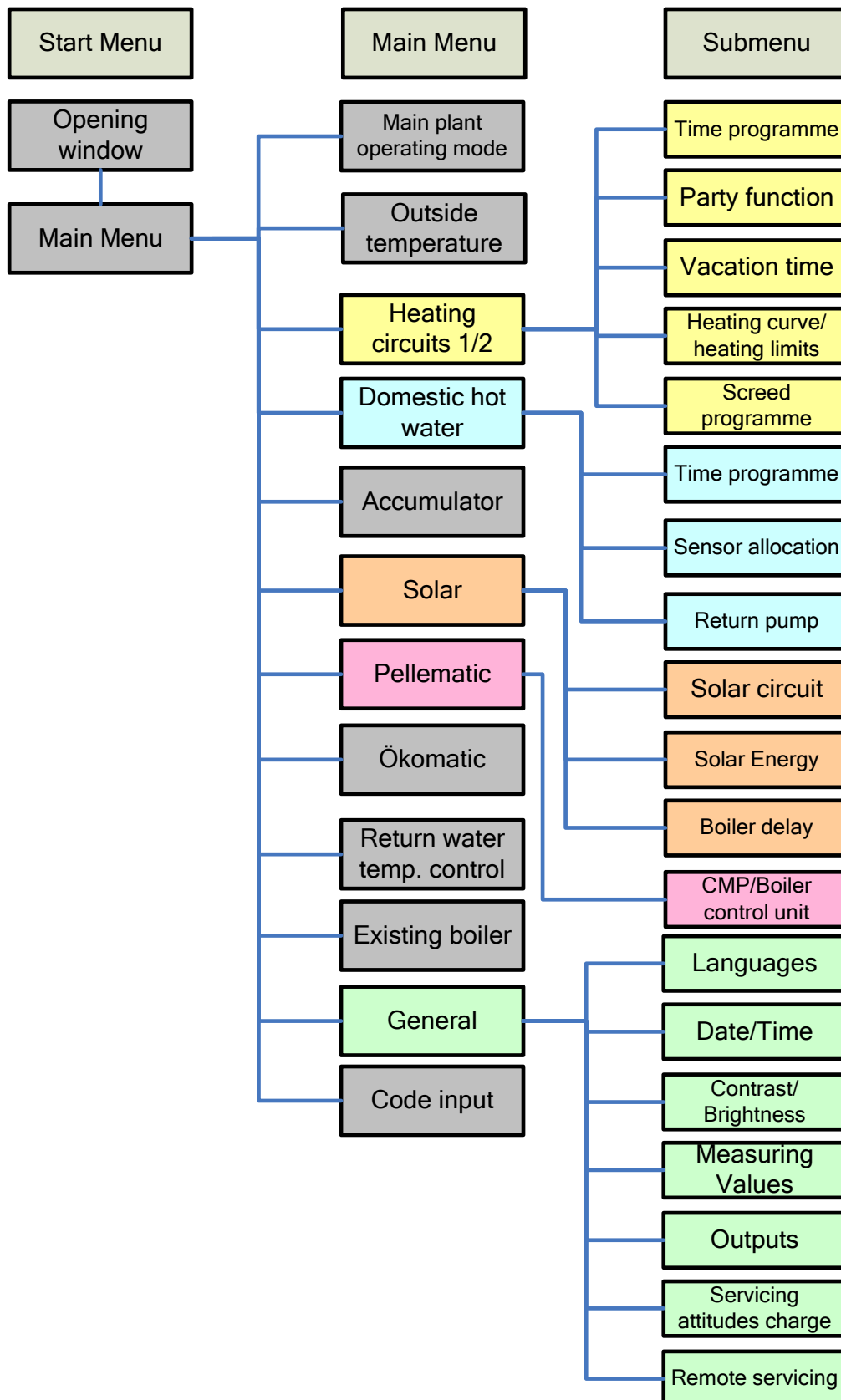

F. MENU GUIDE

1. Main menu

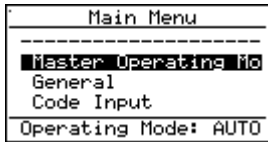

Rotate the **Menu Scroll** to choose the right submenu.

Use the button **Enter** to select the submenu.

NOTICE

These operating instructions explain all the functions available in the Pelletronic controller. Only the equipment in your system that is detected by the controller will be displayed in the menus

2. Master operating mode

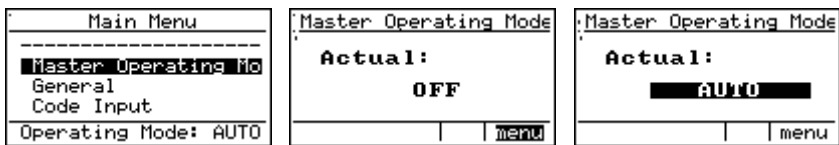

You can choose between 3 operating modes:

- OFF** Heating circuits, set back and domestic hot water off
Frost protection on
- AUTO** Timed heating, set back and domestic hot water on
- DHW** Timed domestic hot water on
Timed heating off
Frost protection function operates

NOTICE

The solar operating mode can be operated independently of the plant operating mode

3. Outside temperature

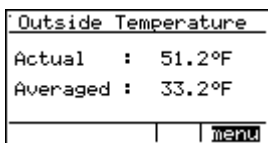

- Actual:** Current outside temperature
- Averaged:** Average outside temperature over last 60 minutes

4. Heating circuit

```
Heat Circuit 01
Operat Mode: OFF
Set Room Temp: 71.6°F
Set Back Temp: 64.4°F
further | menu
```

Heating circuit(s) operation

- OFF** Frost protection only
- AUTO** Timed heating on. Set back during non time periods
- HEATING** Heating on
- SET BACK** Heating on set back temperature continuously
- MANUAL** Boiler is called, heating pumps run, mixing valves disconnected
Will operate when the outside temperature is below summer limit and maximum flow temperature is not exceeded.

NOTICE

The heating timed periods can be adjusted in the submenu heating circuit.

```
Heat Circuit 01
Operat Mode: OFF
Set Room Temp: 71.6°F
Set Back Temp: 64.4°F
further | menu
```

Set room temperature

Adjust your room temperature.

```
Heat Circuit 01
Operat Mode: OFF
Set Room Temp: 71.6°F
Set Back Temp: 64.4°F
further | menu
```

Set back temperature

Adjust the set back temperature.

Set back temperature is the temperature during non timed periods.

NOTICE

The operating mode of the heating circuits can only be changed if the plant operating mode is set to AUTO and no analogue remote control is attached. The adjusted heating limits and max. flow temperatures apply to all operating modes.

4.1. Heating circuit time programme

```
Heat Circuit 01
-----
Time Program 1
Time Program 2
Party Function
Program 1 activ
```

The individual items on the sub menu of the heating circuit are selected in the same way as the main menu.

Each heating circuit has 2 optional time programmes.

They allow set 2 different time programmes.

NOTICE

Only one time programme can be active at a time.

Set the days:

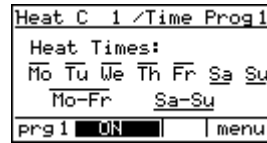
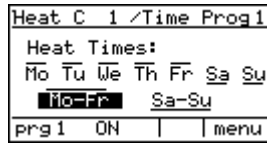
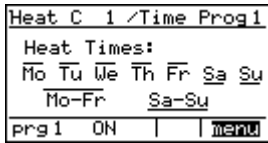

There are the blocks **Mon-Fri** and **Sat-Sun** and individual days **Mon, Tue, ...**

Only 1 time programme may be active at a time. In each individual time programme there are the blocks "Mon-Fri" and "Sat-Sun". When heating times are set in these blocks, they are repeated for each of the days in the block. However individual days can then be modified as required.

The lines over and/or under the individual days show whether the selected heating times on the individual days are identical to the pertinent block. Thus if the heating times e.g. on Wednesday are changed the line disappears over the Wednesday.

Example:

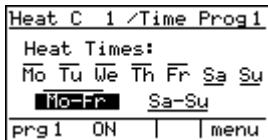

Wednesday:

Other days time programme as Monday – Friday

Select the programme days by highlighting and pressing **Enter**

Adjust the time limits:

Set times for when you want the heating on, the rest of the time the heating will be on set back.

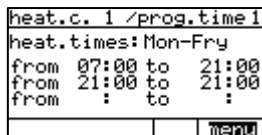

3 heating time periods can be selected for any given day.

Heating times with 1 timed period

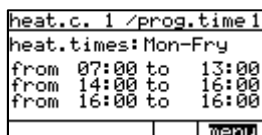

Heating times with 2 timed periods

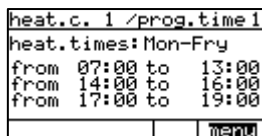

Heating times with 3 timed periods

4.2. Party function

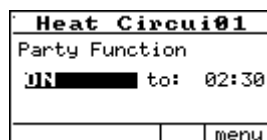
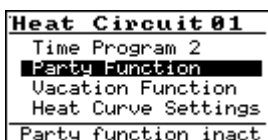

Use the **Party function** to extend the heating time of the selected heating circuit for a single occasion.

The duration of the extension can be chosen - in this case until 02:30am. Once expired, the function becomes inactive again. The heating control returns to programmed settings.

4.3. Vacation function

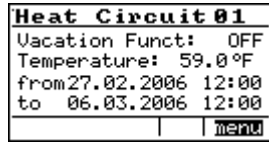
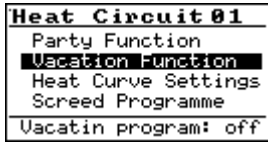

By selecting **Vacation function** a new set temperature can be chosen until a given date after which the usual programme will recommence.

- Vacation function** On or off.
- Temperature** Desired room temperature for the time interval selected
- from** Start time (start of vacation)
- to** Stop time (end of vacation)





CAUTION

Vacation programme should be set for each heating circuit as required, switch off the DHW if not required. When the set vacation date is passed the controller returns to the usual programme, however the programme remains switched On.

4.4 Heating curve settings

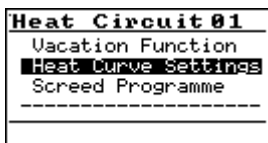
The heating curve and the base point settings determine the flow temperature range to each heating circuit, and reflect the heat loss characteristics of the building and the heating system design.



During handover your ÖkoFEN installer will advise on a suitable heating curve setting. This may then be altered by the user to "fine tune" the system.

- Heating curve:** adjustable from 0.0 – 4.0
- Base point:** adjustable from 68 – 113°F

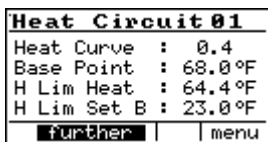

High limit heating: Switches heating off when the outside temperature reaches the set point [user adjustable]

Heating limit setback: The set back function operates when the outside temperature falls below this setting [adjustable]

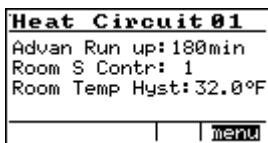

Advanced run up: This function ensures that the set room temperature is reached by the programmed heating time by starting the boiler early. The figure you set is a maximum and will be reduced by the controller depending on the outside temperature as shown in the graph below. We suggest 180mins for underfloor heating in screed and 60-80mins for most radiator systems [user adjustable]

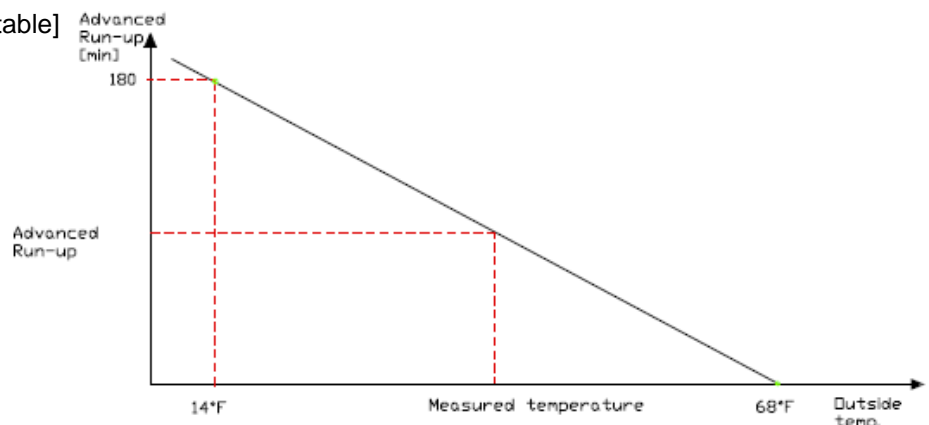

Room sensor control:

In effect this function controls the degree of influence that a given setting on the room thermostat has on the flow temperature to the heating system. Particularly useful in draughty buildings or where there is high passive solar gain.

0 = off Analog room thermostat or the digital remote control are off.

1 - 10 = on Changing the room sensor control parameter from 0 to 1 allows the remote room thermostat to become active. This can adjust the set temperature by $\pm 9^{\circ}\text{F}$.



This indicates, how many degrees the flow temperature is raised or lowered to reach the set room temperature

Example:

Set room temperature = 68°F

Actual room temperature = 66°F



the temperature difference is 2°F

Room sensor control = 3

Flow temperature increase = Room sensor control x Temperature difference

$$6^{\circ} = 3 \times 2$$

Room temperature hysteresis

NOTICE

Only works when an analog room thermostat or a digital remote controller is installed and turned on.

When the room temperature plus hysteresis is reached, the relevant heating pump is stopped. The heating pump starts again when the room temperature is 1.8°F below the set room temperature.

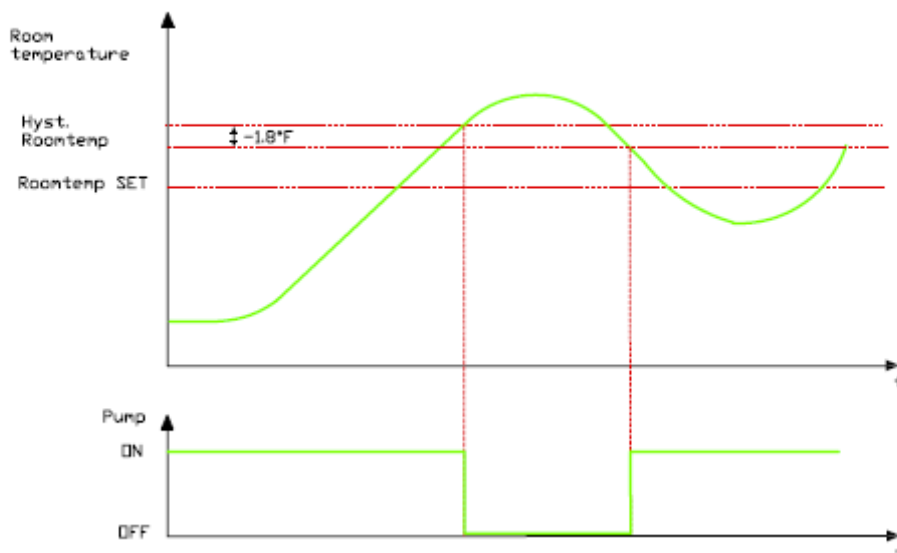

NOTICE



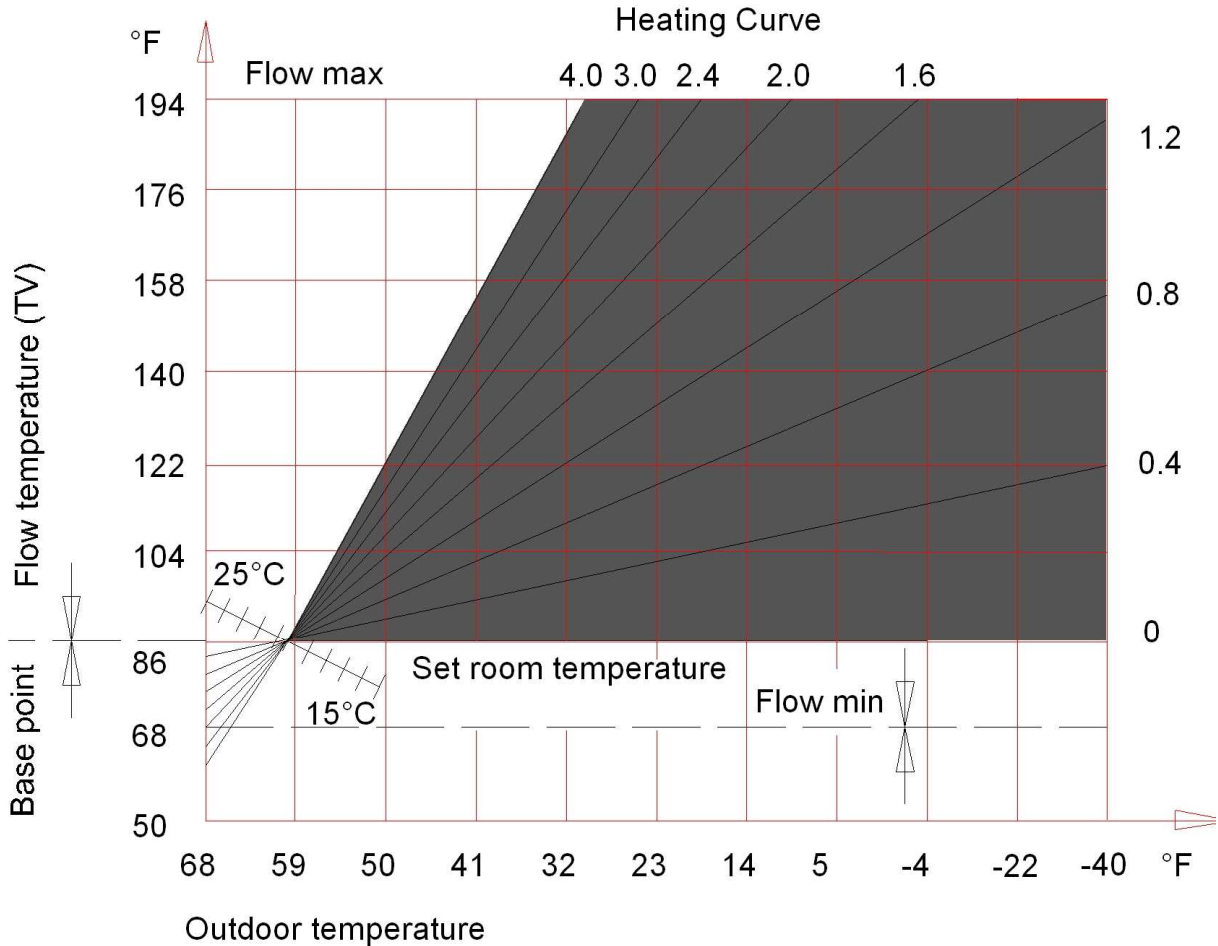



Because of the building's thermal inertia, it is recommended to perform no more than one adjustment step per day.



Adjustment heating curve and base point:

Daytime outside temp	Room temperature	
	Too warm	Too cold
41 to 59°F	Decrease heating curving value by 0.2 <u>and</u> decrease base point value by 8°	Increase heating curving value by 0.2 <u>and</u> increase base point value by 8°
-4 to 41°F	decrease heating curve value by 0.2	incr ease heating curve value by 0.2

4.5 Screed programme

	<p style="text-align: center;"> CAUTION</p> <p>Operation with incorrect settings may cause damage! Consult the floor supplier.</p>
	<p style="text-align: center;"> CAUTION</p> <p>Only use this programme in conjunction with a pump interlock switch positioned on the flow from pump to under floor central heating – this must be set to the max. safe temp. for the conditions of the floor.</p>
	<p style="text-align: center;"> CAUTION</p> <p>No liability is accepted by the Pelletronic supplier for damage to floors or sub floors. Continuous power supply is required to the controller to maintain the settings for this programme.</p>

The screed programme may be operated up to 31 days. A desired flow temperature must be adjusted for each individual day. These temperatures are constant and not dependent on outside temp or room thermostat settings. The function is switched off automatically at the end of the program and the heating circuit reverts to the previous operating mode.

```
Heat Circuit 01
Heat Curve Settings
Screed Programme
-----

```

Setting the days and flow temperatures:

```
HC 01 / Screed Prg
Nu Heating Days: 21
Day No : < 1 >
Flow Set: 68.0
Screed Prg: inact.
inact. | menu
```

Number of heating days, maximum 31 days

```
HC 01 / Screed Prg
Nu Heating Days: 21
Day No : < 1 >
Flow Set: 68.0
Screed Prg: inact.
inact. | menu
```

Scroll days back

```
HC 01 / Screed Prg
Nu Heating Days: 21
Day No : < 1 >
Flow Set: 68.0
Screed Prg: inact.
inact. | menu
```

Scroll days forward

```

HC 01 / Screed Prg
Nu Heating Days: 21
Day No : ◀ 1 ▶
Flow Set: 68.0
Screed Prg: inact.
inact. | menu
    
```

Desired flow temperature

```

HC 01 / Screed Prg
Nu Heating Days: 21
Day No : ◀ 1 ▶
Flow Set: 68.0
Screed Prg: inact.
inact. | menu
    
```

Activate/deactivate screed programme

```

HC 01 / Screed Prg
Nu Heating Days: 21
Day No : ◀ 1 ▶
Flow Set: 68.0
Screed Prg: inact.
inact. | menu
    
```

Back to
main menu

5. Domestic Hot water (DHW)

Main Menu	
Heating Circuit 2	
Domestic Hot Water!	
Accumulator 1	
Solar 1	
OFF /DHW ac: 147.0°F	

DHW 01	
Operat Mode:	OFF
Boost :	OFF
Water Temp :	140.0°F
Water T Min:	86.0°F
further	menu

Operating mode:

- ON** Domestic hot water heated continuously to the set point.
- OFF** Set water temperature is reduced to 8° for frost protection.
- AUTO** Domestic hot water will be heated to the set temperature during time periods.

The operating mode of DHW can only be changed, if the operating mode plant is set to **AUTO** or **DHW**.

Boost:

DHW 01	
Operat Mode:	OFF
Boost :	OFF
Water Temp :	140.0°F
Water T Min:	86.0°F
further	menu

If boost is **On**, domestic hot water heated to the set point on a single occasion.

Water temperature:

DHW 01	
Operat Mode:	OFF
Boost :	OFF
Water Temp :	140.0°F
Water T Min:	86.0°F
further	menu

Set the water temperature.

Water temperature min.:

DHW 01	
Operat Mode:	OFF
Boost :	OFF
Water Temp :	140.0°F
Water T Min:	86.0°F
further	menu

Set the minimum water temperature.

Minimum water temperature is on outside time period and when the domestic hot water is set to Auto or DHW

5.1. DHW time programme

DHW 01	
Time Program 1	
Time Program 2	
Program 1 ON	

DHW 1 /Time Progl	
Heat Times:	
Mo Tu We Th Fr Sa Su	
Mo-Fr Sa-Su	
prg1 ON	menu

Setting DHW time programme is the same as setting heating circuit time programme.

The domestic hot water time programme works the same way like the heating circuit time programme.

See page 12 **Heating circuit time programme**

5.2. Sensor allocation (combination tanks only)

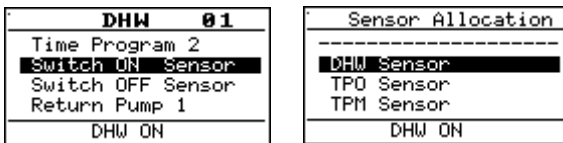

The switch off sensor is only shown, if combination tank is fitted and selected in the Pelletronic menu! This function allows allocation of the sensor used for determining DHW set point (TPO [upper sensor], TPM [middle sensor], TPU lower sensor)

It is important to install the DHW sensor to the I/O Box in order to activate the DHW programme.

When the combination tank programme is selected, you can allocate the sensors.

NOTICE

Do not use TPO as switch off sensor, the TPO can only be a switch on sensor!

DHW, TPM and TPU can be used as switch on and switch off sensors.

TPU is normally used as solar return sensor. If the DHW sensor is selected, use the hysteresis to change the temperature difference on the selected switch off sensor.

5.3. DHW Return pump

The return pump circulates the domestic hot water, when a secondary return is fitted.

When this function is switched on you can see and set the time programme.

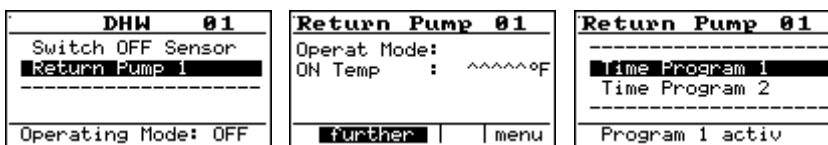

Operating mode: Choose between **AUTO** and **OFF**.

ON temperature: The point at which the pump starts.

Is the domestic hot water temperature below the settled **ON temperature**, the return pump is off.

Time programmes: Select a time programme and set it. See also page 12

6. Accumulator

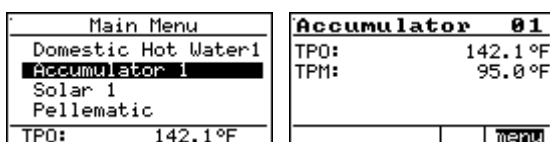

Accumulator information only

Display of actual temperatures:

TPO: AC upper temperature of upper sensor

TPM: AC middle temperature of middle sensor

7. Solar

Main Menu	
Accumulator 1	
Solar 1	
Pellematic	
General	
Coll act:	129.7°F

Solar 01	

Solar circuit 1	
Solar circuit 2	
Solar energy	
TPU 1:	116.6°F

7.1. Solar submenu

Solar 01 Circ. 1	
Operat Mode: OFF	
Coll Temp :	129.7°F
TPU :	116.6°F
further	menu

Operating mode:

ON Solar system is on

OFF Solar system is off.

Coll temp Displays actual collector temperature

TPU: Displays actual DHW temperature

NOTICE

The solar system can be switched on/off irrespective of the plant mode.
The operation mode SOLAR can also be changed, if the **OPERATING MODE PLANT** is set on **OFF!**



WARNING

Very high domestic hot water storage temperatures are possible!

Solar 01 Circ. 1	
Sol Pump ON :	50.0°F
Sol Pump OFF:	41.0°F
TPU Max :	140.0°F
TPU Hyst :	41.0°F
further	menu

Solar 01 Circ. 1	
Coll Smoothing:	OFF
Coll T Min :	140.0°F
Contr Range:	50.0°F
	menu

Solar pump switch ON: The difference between collector and Solar return (TPU) is greater than the set temperature.

Solar pump switch OFF: The difference between collector and Solar return (TPU) is less than the set temperature.

TPU max: The solar pump is switched off, when the DHW set point is reached.

TPU hyst: The solar pump is switched on again, when the temperature of DHW falls below set point minus the hysteresis.

The **TPU hysteresis** prevents the solar pump cycling.

Collector smoothing:

It only functions on solar circuit one, it can be switched on and off and it ensures an efficient delivery of energy from the collectors.

NOTICE

Collector smoothing can only be set, when the speed control function is on in the code protected parameters.

**Collector temp min/
Control range**

At this temperature the solar pump starts to run at minimum speed. The pump speed increases within the set range as the collector temperature increases.

7.2. Solar energy

This function measures the yield of the solar system
Displays current energy and logs previous days.

NOTICE

For the function solar energy it is necessary to install:
Pulse volume meter, temperature sensor and return temperature sensor:
We recommend consulting your specialist installer before changing these settings

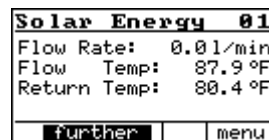
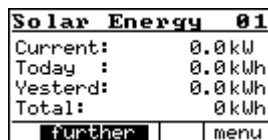
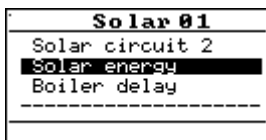

- Current (kW):** Display of the current solar energy (refreshes every 60 sec)
- Today (kWh):** Display of today's solar energy since 00:00.
- Yesterday (kWh):** Display of the of yesterdays solar energy
- Total (kWh):** Display of the solar energy since the last set date
- Flow rate (l/min):** Refreshes every 60 sec.
- Flow temp (°F):** Display of the current flow temperature
- Return (°F):** Display of the current return temperature

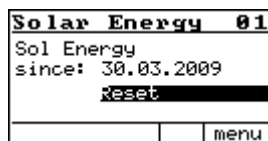
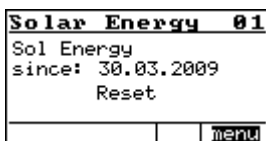

- Solar energy:** Display of the calculation of the total solar energy.
- Reset:** Reset the total solar energy back to zero. The actual date is the new start date for the solar log.

7.3 Boiler delay

This can only be set in the code protected parameters. The boiler delay is only possible, when the heat exchanger of the solar plant is in the accumulator. The boiler delay holds the boiler off, whenever the solar collector is above the minimum temperature and the temperature is within the delay time.

Solar 01	SWH Boiler Delay	SWH Boiler Delay
Solar Energy	Boiler Delay: inact.	Boiler Delay: inact.
Boiler Delay	Delay Time : 0 min	Delay Time : 0 min
-----	Temp Rise : 32.0 °F	Temp Rise : 32.0 °F
	menu	menu

8. Pellematic

Main Menu	Pellematic	Pellematic CMP	Pellematic 01
Solar 1	Boiler Temp : 147.2 °F	pellematic 1	Pellets Control
Pellematic	Boiler T set: 46.4 °F	Pellematic 2	147°F Standby
General	pellematic 01	Pellematic 3	State: Standby
Code Input			KT: 147°F RGT: 507°F
Actual: 127.5 °F	menu	Menu	

- Boiler temp:** shows the actual boiler temperature
- Boiler temp set:** shows the set boiler temperature, calculated to meet the highest temperature requirement at the time (e.g. hot water 140°F + 18 °F excessive temp.)
- Pellematic CMP** shows the number of installed boilers (default = 0)

NOTICE

You only see the in **Learning Periphery** activated boilers

Pellematic 01: You are in the boiler control CMP from boiler 01

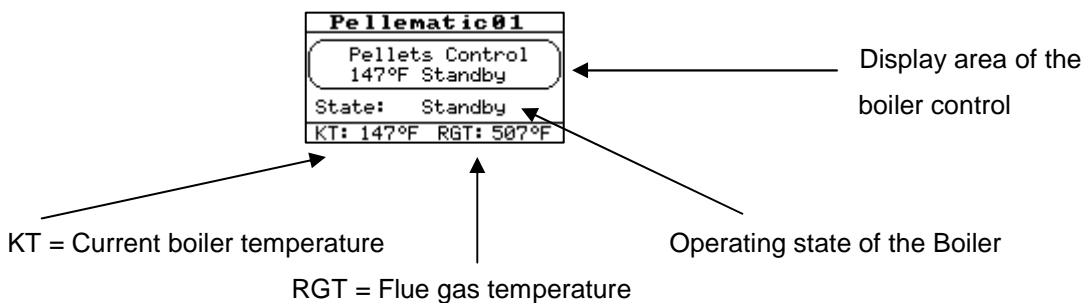

Pellematic 01	Pellematic 01	Pellematic 01
serial number P101: 000046	Manual override P104: Push key	Boiler Temp. P105: 147°F
State: Standby	State: Standby	State: Standby
KT: 147°F RGT: 509°F	KT: 147°F RGT: 509°F	KT: 147°F RGT: 509°F

By turning the **Menu scroll** you get to the menu of the **heating controller**. Press **Enter** to set parameters.

9. Ökomatic (Wood log boiler)

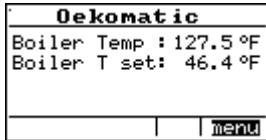

Boiler temp.:

shows the actual boiler temperature

Boiler temp set:

shows target temperature for the boiler, calculated to meet the highest temperature requirement at the time (e.g. hot water 140 °F + 18 °F excessive temp.)

NOTICE

Pellematic and Ökomatic can't be selected at the same time.

Ökomatic Warning:

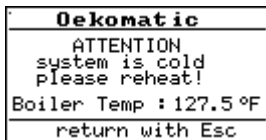

A warning message appears, if there is a boiler call and the temperature of the Ökomatic boiler is below 113°F. The burner demand has no effect on the Ökomatic, only a warning is issued.

The warning message clears given the following conditions:

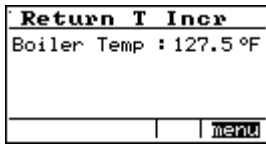

- No burner call
- Boiler temperature rises by 9°F
- Boiler temperature is above 113°F
- ESC is pressed

10. Return Temperature Increase

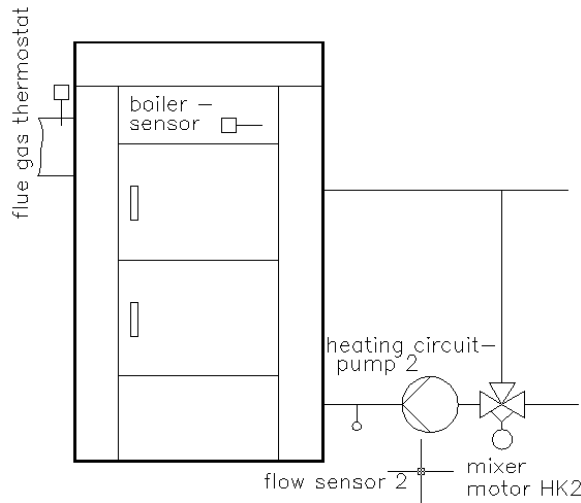

Boiler temp: shows the actual boiler temperature



	 CAUTION
<p>Use Return Temperature Increase only with the combination Pellematic, Thermomat and Accumulator. This function requires I/O Box E1228 heating circuit 2 of the first I/O box must be used!</p>	

NOTICE
<p>If the return temperature increase is active, Pellematic is not displayed in the main menu, as in this menu are no relevant information. Pellematic will not respond to this boiler sensor, as it is in Thermomat. It only responds on the buffer sensors (TPO and TPM)</p>

11. Existing boiler

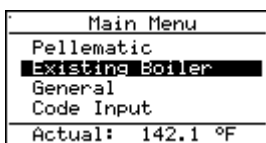

If there is an Existing boiler used in the system, the Pelletronic heating controller recognizes it automatically. In this case the sensor TPO is used as boiler sensor. The TPO is displayed as **Boilert Ac**. When the Existing boiler reaches the ON temperature, the Pellematic turns of and the plant uses the energy from the Existing boiler.

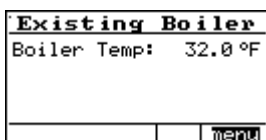

Boiler temp: Shows the actual boiler temperature.

The TPO in the Existing boiler is used as boiler sensor.

NOTICE
<p>The return temperature increase is not regulated by the Pelletronic Plus.</p>

12. General

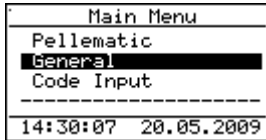

Access to general system information and settings

12.1. Languages

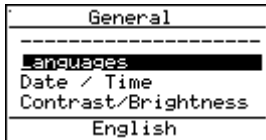

Select the language

12.2. Date/Time

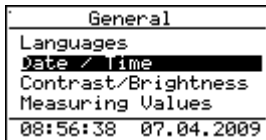

Use this setting to set the date and time

NOTICE

In the case of a power failure of more than 2-3 days clock time is lost, and parameter settings may be lost. When the power is back, set the new date and time. There is an automatic adjustment to seasonal time.

12.3. Contrast/Brightness

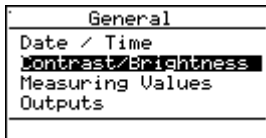

Adjustment of the contrast, the brightness and the duration of the background lighting

12.4. Measuring values

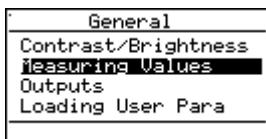

Display of all SET and ACTUAL temperatures in the plant

This provides a most useful view of the heating system status

12.5. Outputs

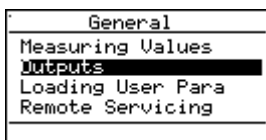

Display of all outputs in the plant. Allows remote verification of pump and valve settings.

Exception: Accumulator pump – controlled by the boiler

12.6. Saving user parameters

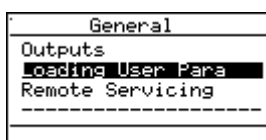

Loading the parameters previously saved by the service technician.

If no parameters have been changed, the default values will be saved.

12.7. Remote servicing

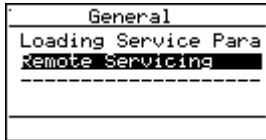

This function is optional. The necessary additional hardware is extra available from your ÖkoFEN distributor.

NOTICE

- Please refer to operating instructions for the TC35i supplied with unit.
- The remote control only is available in German and

13. Code input

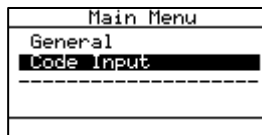

CAUTION

Only accessible by authorized specialists! They can adjust further settings after entering the code.

G. START UP

	 CAUTION
<p>Settings in the code-protected parameters may only be adjusted by qualified personnel.</p>	

<h3 style="margin: 0;">NOTICE</h3>
<p>The code expires automatically, on return to the main menu. By entering the code additional functions appear in the different levels of the menu structure.</p>

Plans of different hydraulic systems are available on request from your ÖkoFEN national distributor.

1. Learning periphery

<pre> Main Menu Code Input Learn Periphery Sensor Calibration Room Thermostat </pre>	<pre> Per ipheru No of I/O Boxes : 1 No of Slave Units: 0 Boil Type: Pellematic RT Increase: OFF further </pre>
--	---

In **Learning periphery** you adjust witch participants are available for the system. After **Learning periphery** the heating controller displays all connected items of hardware in the main menu. Now you can make further settings. Learn periphery whenever sensors are changed or any other connection is changed in the I/O box.

Number I/O (input/output units):

number of I/O boxes is adjustable (1 – 3).

Maximum of 6 heating circuits per Pelletronic heating controller



I/O-box address setting

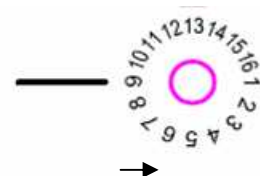

<h3 style="margin: 0;">NOTICE</h3>
<p>When using more than 1 I/O Boxes ensure that each I/O Box has its own address with No.1 for boiler and outside sensor and at least 1 heating circuit flow temperature</p>

Number of slave units:

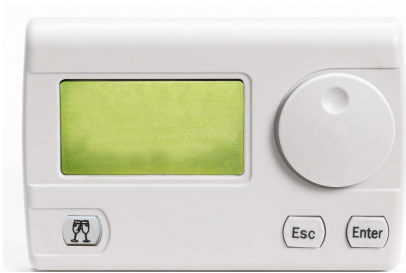

The number of digital remote controllers must be set (0-6).

NOTICE
Pay attention to the operation instruction of the digital remote control. It is added to the digital remote control.

Boiler type:

Select Pellematic.

Return temperature increase:

Select No

Exception:

Change to Yes only by using a Thermomat
Return temperature increase is to be used on the second heating circuit of the I/O Box 1.
See return temperature increase page 30

NOTICE
If an accumulator is in the system, TPO and TPM sensors must be connected. TPO sensor must be fitted just below flow pipe to pump station and TPM sensor must be fitted just above return pipe from the pump station.

NOTICE
If only the TPO sensor is connected, the controller detects no accumulator. The Pelletronic interprets this as a second boiler. After each time Learning periphery it's necessary to reset the combination/multi storage tank setting back on

	CAUTION
Boiler sensor and Outside sensor must be connected to the first I/O unit (Address 1)	

Pellematic CMP:

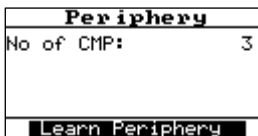

Enter the number of Pellematic CMP (Default = 0)

NOTICE
If there are 2, 3 or 4 Pellematic CMP, the Pellematic plugs 1 to 4 have to be inserted to Input RGF 10 11 of the respective boiler control. After Learning Periphery you see all activated Pellematics in the menu point Pellematic CMP

2. Ökomatic

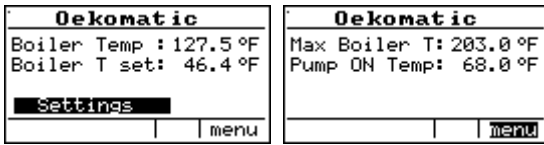

Boiler temp Max: Set the Boiler temperature maximum.

When Ökomatic reaches the Boiler temp Max, all pumps start for using all the energy from the boiler.

This process stops, when the boiler temperature falls below the Boiler temp Max minus the adjusted difference.

(e.g.: BT Max. 203F minus difference 12.6F = 190. 4F)

Pump start: Pump start temperature

When the boiler temperature reaches the **pump start**, the pumps start to run

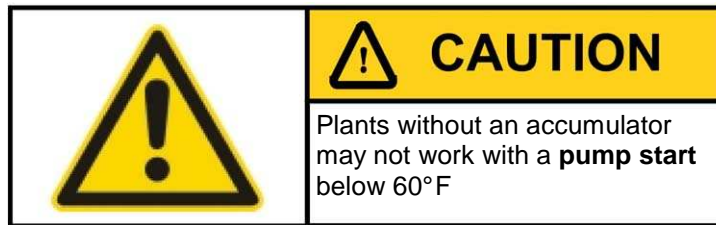

3. Return temperature increase

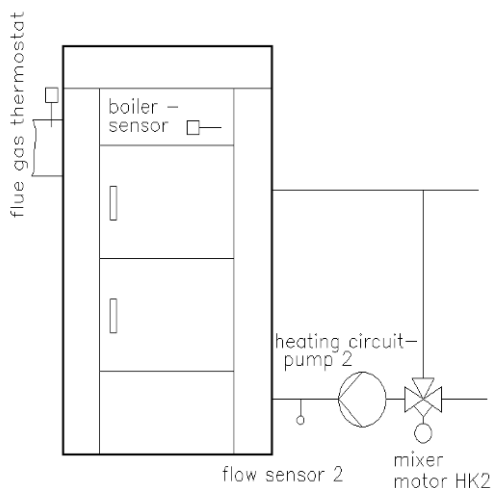
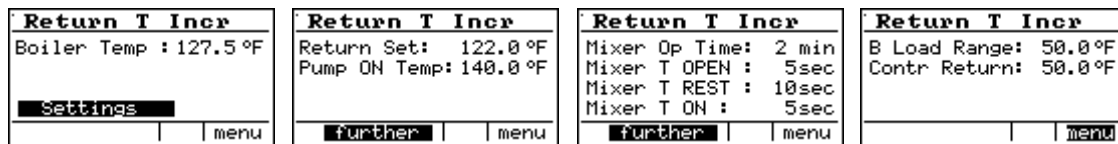

For the **Return temperature increase** use the circuit heating at the 1. I/O-Box. It is connected with flow sensor 2, 2 and heating circuit pump 2.

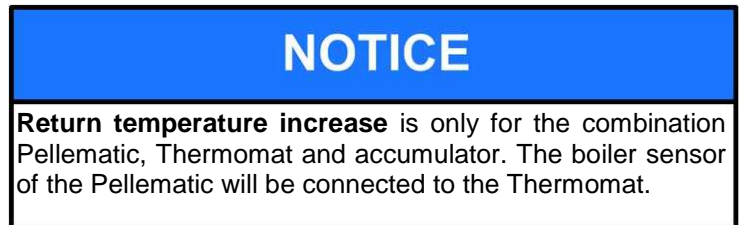

4. Existing boiler

The menu existing boiler controls the interaction of the existing boiler and the Pellematic. When the Existing boiler reaches the ON temperature, the Pellematic turns of and the plant uses the energy from the Existing boiler.

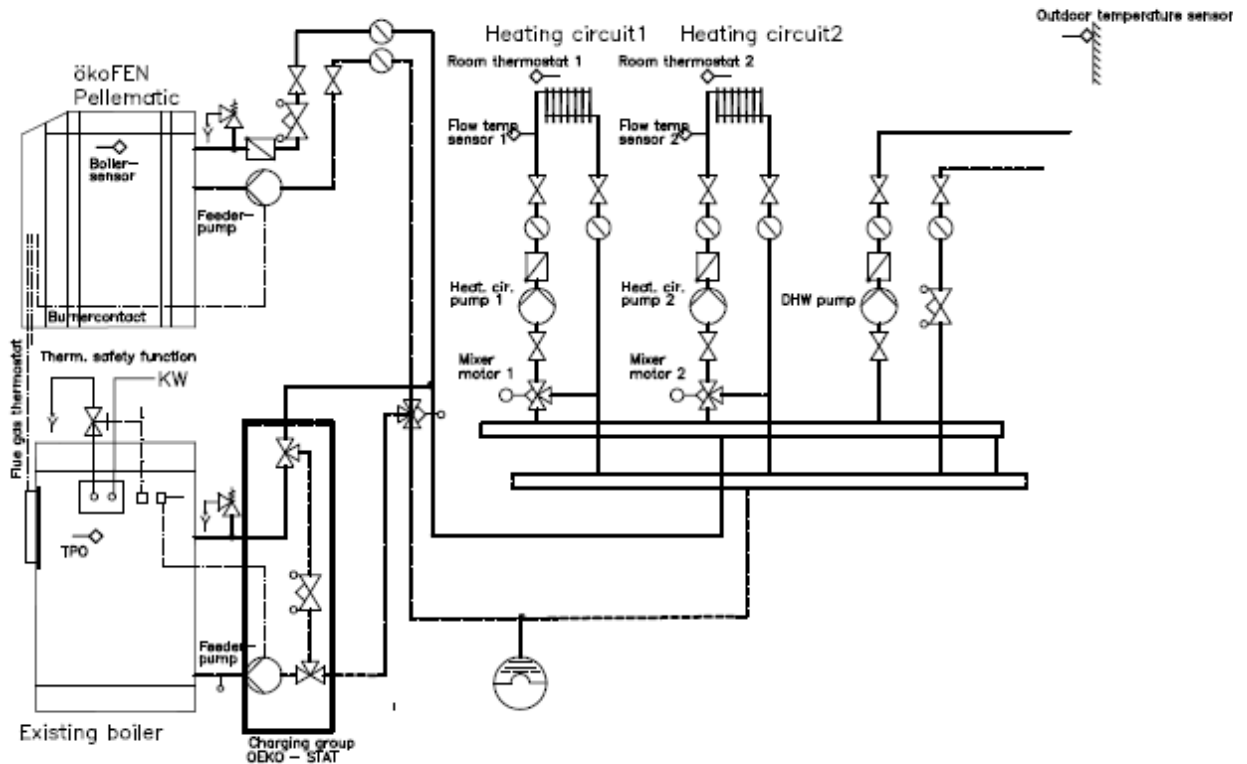

Existing boiler is active, if the heating controller detects only 1 accumulator sensor TPO, see

Learning periphery page 28. The TPO has to be connected with the I/O Box 1. There cannot be an accumulator, because the sensor TPO is used as boiler sensor for the existing boiler.

NOTICE

When the Existing boiler reaches the On temperature of the valve inversion, also when there is no demand for the boiler, the DHW will be heated and afterwards the heating circuits.



CAUTION

The function existing boiler is only used for log boilers and it cannot include an accumulator.

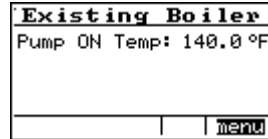
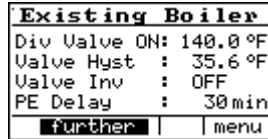
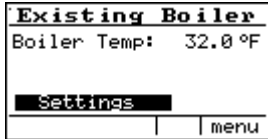

- Diverter valve ON:** The start temperature of the diverter valve.
 The diverter valve is connected to the spare output
 When the diverter valve is switched to the existing boiler, the Pellematic is shut down!
- Diverter valve hysteresis:** Prevents cycling of the diverter valve.
 e.g.: With a diverter valve start temp 140°F and a hysteresis of 3.6°K, the diverter let switches with 136.4 °F.
- Diverter Valve inversion:** This allows inversion of the switching of the valve to accommodate an existing diverter valve.
- Pellematic delay:** When the temperature of the existing boiler falls below the start temp, only after expiring the **off time** will be a new demand to the Pellematic.
- Pump start:** When the existing boiler reaches this temperature, the DHW and Heating circuit pumps start.

NOTICE	
The maximum temperature for both boilers can be set!	

	 CAUTION
	Return temperature increase of the existing boiler, is not controlled by the heating controller Pelletronic Plus.

5. Sensor calibration

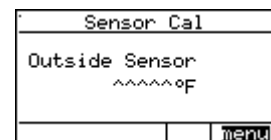
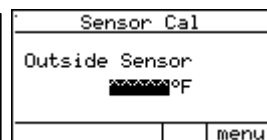
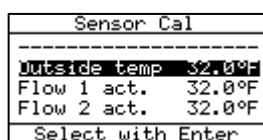
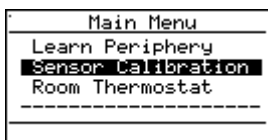

This function allows the displayed value of each sensor to be calibrated for + or – 9°F. This may be necessary with long lengths of the cable.

NOTICE	
Only sensors found during Learning periphery are displayed.	

6. Room thermostat



The room thermostat measures the room temperature and compares it with the set room temperature. The flow temperature will be adjusted, depending on the room sensor control.
(See room sensor control p. 15)

Assignment: Assign the room thermostat to the right heating circuit.

Room sensor: Activate the room thermostat of the controller for wall fastening

NOTICE

The room sensor can only be assigned to a heating circuit without a sensor!

7. Heating circuits settings

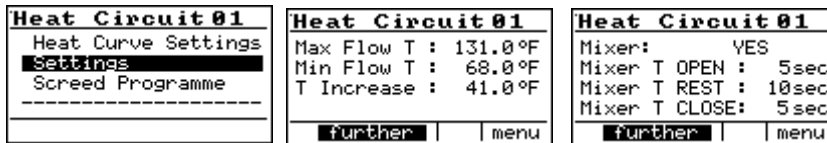

Max Flow temperature:

Sets the maximum flow temperature to the selected heating circuit.

NOTICE

This should not be used as the only protection against over temperature to the heat circuit.

Min Flow temperature:

Sets the minimum flow temperature to the selected heating circuit.

NOTICE

The flow temperature will not fall below this point irrespective of other controller settings.

Temperature increase:

(System heat loss adjustment)

Sets the boiler or accumulator temperature above the set flow temperature of the circuit calling for the highest temperature.

E.g.: Set at 9°F with a heating/DHW circuit with a set temperature of 140°F the minimum boiler / accumulator temperature will be set to 149°F. The boiler is not called when boiler/accumulator is above the minimum temperature.

- Mixer Yes/No:** Select type of valve used to control heating circuits.
 There are heating circuit with mixer motor or direct heating circuit
- Mixer time open:** opening time of the mixer
- Mixer time rest:** rest time between open and close of the mixer
- Mixer time close:** closing time of the mixer

Heat Circuit 01	
B Load Range:	°F
Flow Range :	50.0°F
Mixer Op Time:	2 min
further	menu

Boiler load range:

The mixer opening speed increases with boiler temperature in the set range.

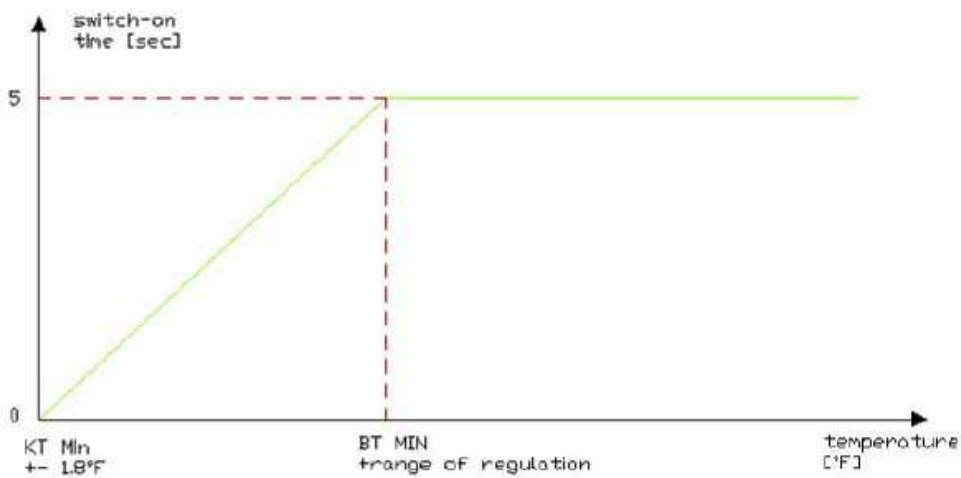

Flow range:

This function dynamically reduces the rate at which the mixer operates to reduce boiler cycling, particularly useful when starting systems with high load.

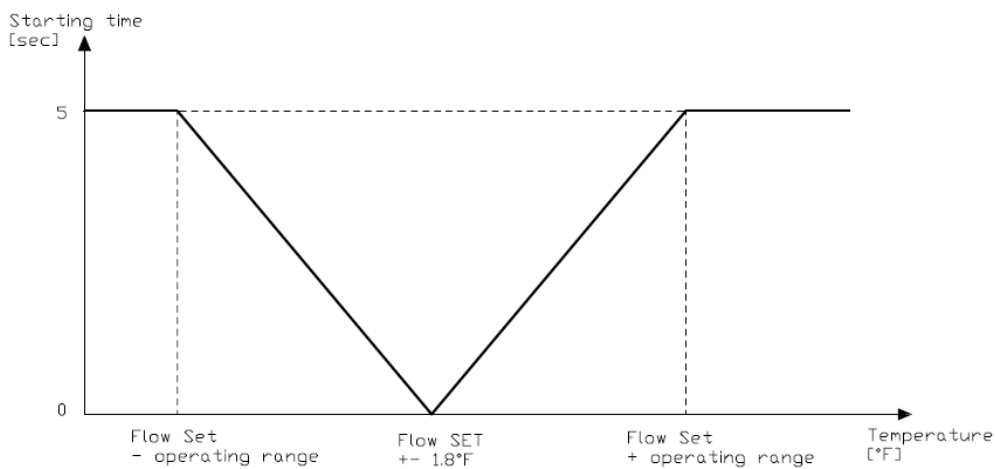

Mixer operating time:

Adjusts the time the mixer opens or closes completely.

Boiler temperature smoothing:

The boiler temperature smoothing controls the boiler load by smoothing the operation of the mixer. This function operates, when the boiler temp fails to rise above the boiler temp min plus the boiler temp rise, this function influences the mixer, therefore helping to maintain the boiler temperature.

NOTICE
The boiler temperature smoothing operates only on systems without accumulator.

Heat Circuit 01	
Boiler Temp Smoothing	
Min Temp Rise: 36.5°F	
B Load Range : 42.8°F	
Rise Time: 1 min	
	menu

Boiler load control range: Is the temperature range within the Pelletronic measures.

Minimum Temp/Rise time: This is the minimum temperature rise required over the rise time

- 1 The boiler temperature rises or exceeds the minimum temperature within the set rise time. The Mixer opening time is not influenced.
- 2 The boiler temperature remains steady within the set rise time. The mixer stays in the same position.
- 3 The boiler temperature falls within the set rise time. The mixer starts to close.
- 4 The boiler temperature rises or exceeds the minimum temperature within the set rise time. The Mixer opening time is not influenced.

8. Domestic hot water settings

DHW 01
Return Pump 1
Settings

DHW 01
DHW Priority: ON
T Increase : 50.0°F
Pump Run on : 10 min
Hysteresis : 41.0°F
further menu

DHW 01
Legionella Protect:
Monday
DHW Return Pump:
inact.
menu

DHW priority: The hot water priority can be switched on or off. DEFAULT is ON. Useful for combination tanks with radiator systems.

When ON, the heating circuits will not run until the DHW reaches the set point. When OFF, the DHW and heating will operate in parallel.

Temperature increase: This increases the DHW set temperature.

E.g. Use this function to over come heat losses in connecting pipe work.

Pump run on:

This function is set in minutes and determines the run on time of the DHW pump. This allows residual energy in the boiler or accumulator to be transferred to the DHW cylinder.

E.g. 10 min or when boiler temp is lower than DHW cylinder which ever occurs first.

Hysteresis:

Maintains the temperature of the DHW within this range during a timed or manual ON period. Only functions when the operating mode of the DHW has to be on or auto. If the operating mode is set auto, there has to be a demand for the burner

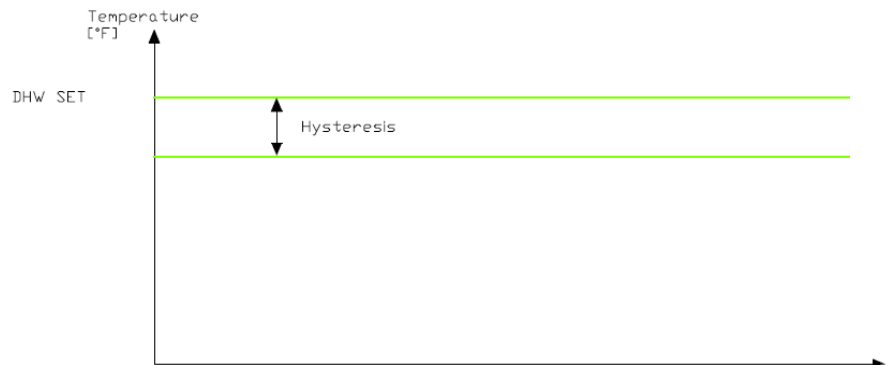

Legionella Protection:

Raises DHW cylinder temperature to Legionella pasteurisation temperature, 149°F on selected day each week.

You can deactivate this function.

	 DANGER
Full pasteurisation may not be possible in some types of cylinder due to position of boiler coil or other considerations, consult relevant cylinder manufactures for details. Risk of Scolding from very hot water!	

DHW Return Pump

You can activate and deactivate the return pump. You can activate 1 return pump or 1 booster pump per I/O box.

9. Return pump settings

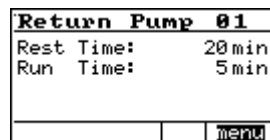
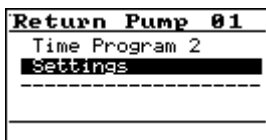

Functions with a separate time programme.

Rest time: pump resting

Run time: pump running

10. Accumulator settings

Accumulator 01	Accumulator 01
TPO: 142.1 °F	Ac Temp Max: 86.0 °F
TPM: 95.0 °F	Ac Temp Min: 50.0 °F
Settings	Combined Ac: OFF
menu	menu

The Pelletronic heating controller detects the accumulator automatically, when sensors TPO and TPM are installed.

Accumulator temperature Max:

The maximum set point varies according to the highest temperature required by the controller. If there is no demand, the accumulator is loaded to the **accumulator max**.

This set point is measured by the middle sensor TPM (= Turn Off Sensor)

Accumulator temperature Min:



When the accumulator temperature falls below the minimum temperature measured by the upper sensor TPO the boiler is called to load the accumulator to the set point.

Multi combination accumulator:

When sensors TPO and TPM are detected by the controller when learning periphery the controller function automatically switches to accumulator control.

If a combination tank is installed this must be activated in accumulator settings menu.

In this menu one of 4 sensors TPO, TPM, DHW and TPU may be assigned to the act as the controlling sensor for the DHW function of the combination tank. This determines the volume of DHW available.

	 CAUTION
	Each time learning periphery is enabled the combination tank setting defaults to NO. The sensor assigned to DHW loses its function until re-set as indicated above. The minimum requirement is: TPO, TPM and DHW sensor

11. Solar settings

Solar 01 Circ. 1	Solar 01 Circ. 1	Solar 01
Coll Smoothing: OFF	Switch OFF: TPU	Pump Type: Class A
Coll T Min : 140.0 °F	Coll Temp Max: 266.0 °F	Speed Control: OFF
Contr Range: 50.0 °F	Hyst Collect : 86.0 °F	Type Sp Control: 0-10U
setting	further	further
menu	menu	menu

Solar switch off:

Select the sensor to be used for the cylinder/accumulator/combination tank set point. This switches off the solar input to the DHW cylinder / combination tank. Only the sensors installed and found during learning periphery are shown in this list.

	 DANGER
	Risk of Scolding from very hot water!

If the low sensor (TPU) is selected as the set point "switch" high temperatures can occur at the top of the cylinder.

Collector Temperature Max:



When the collector reaches the collector temperature maximum, the solar pump switches off.

Collector Hysteresis:

This is the start temperature for the pump as the temperature of the collector falls. It prevents cycling

Pump type:

Choose between A category pump and standard pump.

	 CAUTION
	<p>If the pump speed control is on, standard pumps can be damaged.</p>

Speed control On/Off

The speed regulation of the solar pump can be switched on and/or off.

Only functions with suitable pumps.

Type of speed control:

Speed control is only possible with A category pumps. You can choose between Analog and PWM.

NOTICE
<p>2 different types of A rated pumps: 1. Analog pumps with 0-10 V control 2. PWM pumps with 24V control. For each type of pump you have to adapt the I/O BOX and the Pelletronic settings.</p>

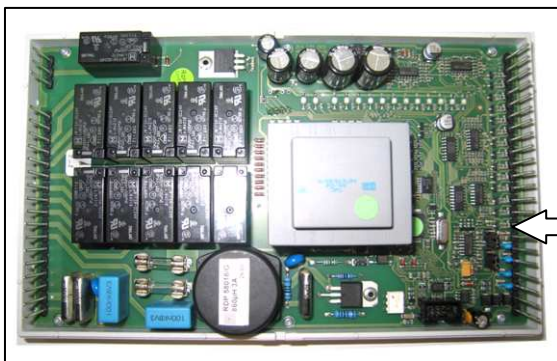

Backside I/O-BOX

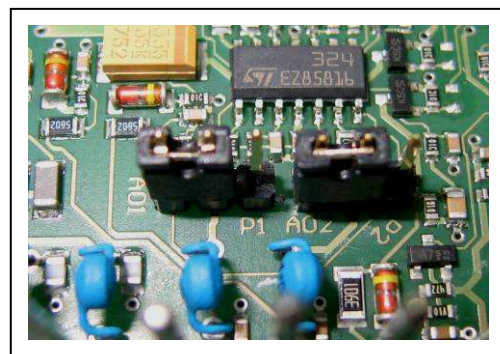

Jumper (Analog or PWM)

Jumper position:

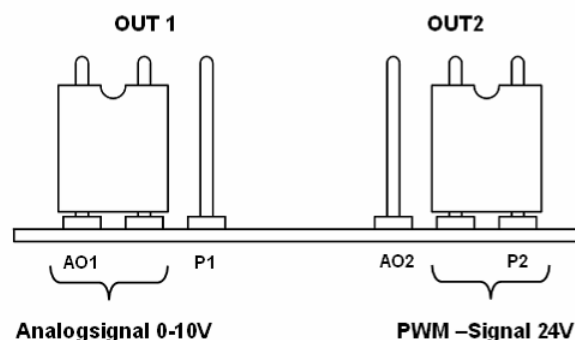

Solar 01	
Priority :	1
Run Time :	min
Rest Time :	min
Scav Time :	sec
	MENU

Priority PRIO 1 and PRIO 2:

Systems with more than on solar hot water cylinder/combination cylinder
 Select priority of solar cylinders. Allows cascade function loading of cylinders.
 Cylinders can be loaded in series cascade or in parallel.

Solar pump pulse program for PRIO 2:

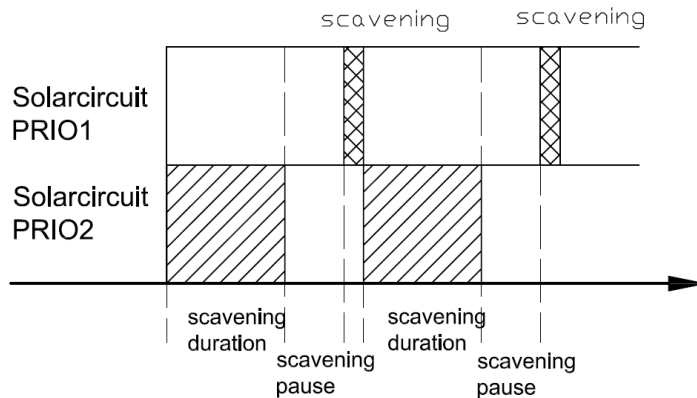

Set the solar pump pulse programme for solar circuit PRIO 2
 Only for solar circuit PRIO 2 it is necessary to set the solar pump pulse programme.

After the scavenging period of solar circuit PRIO 2 follows the scavenging interval of both solar circuits.
 After the scavenging interval follows the scavenging time.
 During the scavenging time the solar circuit checks, if there is a new demand for PRIO 1 or not.
 If there is a demand for solar circuit 1, the pump will run, if not the scavenging period of solar circuit 2 starts. If during the scavenging period of solar circuit 2 there is a demand from solar circuit 1, it will be immediately fulfilled.



Number of solar pumps:

- Choose between 1 and 2:
- 1.....2 Solar circuits with 1 solar pump and 1 motorised valve
 - 2.....2 Solar circuits with 2 solar pumps

	 CAUTION
	<p>Connections in the I/O Box for solar pump and motorised valve</p> <p>Solar pump connect to solar pump 1</p> <p>Motorised valveconnect to solar pump 2</p>

2 Solar circuits with 1 pump and 1 motorised valve

Solar circuit 1.....Priority 1

Solar circuit 2.....Priority 2

Example of 1 solar circuit with 1 pump and 1 motorised valve

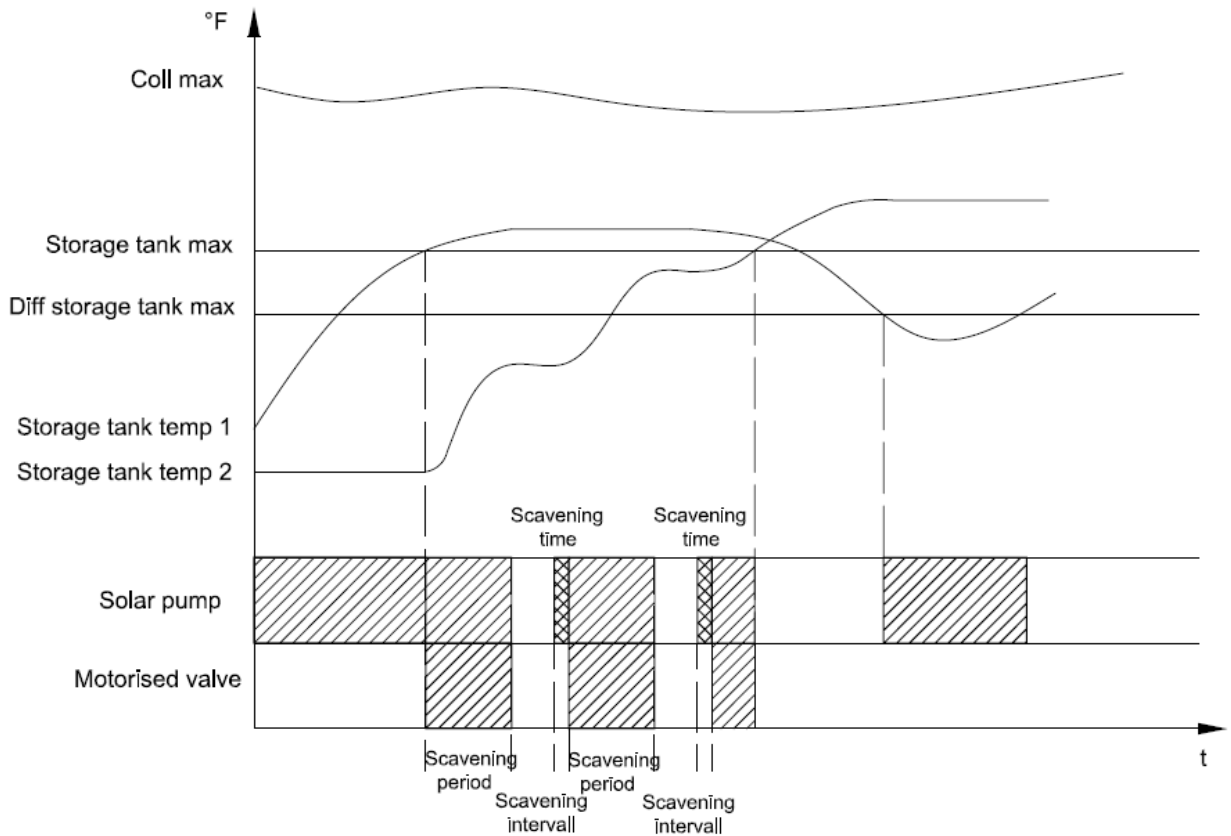

2 Solar circuits with 2 pumps

Operates as with 1 pump but both pumps in parallel

Minimum temp diff:

This setting is displayed only when 2 solar pumps and 2 heat exchangers are installed.

If the Temperature difference between collector and accumulator (TPU) of PRIO 1 is greater than the **minimum temp diff** both solar circuits run.

12. Solar energy

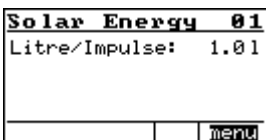

Litre/impulse:

Adjust the setting according for the volume meter use!

NOTICE

Default is 1 litre for the ÖkoFEN solar yield set.

13. SWH Boiler delay

SWH Boiler Delay Boiler Delay: inact. Delay Time : 0 min Temp Rise : 32.0 °F setting menu	SWH Boiler Delay Delay Time: 30min Temp Diff : 41.0°F Temp Rise : 33.8°F Rise Time: 10min further menu	SWH Boiler Delay Coll Temp min:140.0°F menu
---	--	--

- Delay time:** Set the duration of the boiler delay.
- Temp diff:** Set the Temp diff max between TPO and TPO set
- Temp rise:** The Min temperature rise at the TPO
- Rise time:** The time during which the temp increase is measured
- Coll Temp min:** The collector temperature minimum

The boiler delay operates when:

- The operating mode of the solar circuit is on
- The boiler delay is on
- The maximum temperature difference is not exceeded
- The Rise temp is higher than the set rise temp within the rise time
- The collector temperature is higher than the collector minimum

14. Heat Main Circulation

Pellenatic Boiler Temp : 127.5 °F Boiler T set: 46.4 °F Heat Main Circ settings menu

The **Heat Main Circulation** pumps primary water, when the boiler is separated from the pump stations.

Heat Main Circ Heat Main Circul. 1 Pump 1 active

Choose the number of Heat Main Circulation Systems. Maximum is 1 per I/O box up to 3 I/O boxes.

Heat Main Circ 0 Operat Mode: OFF Component
--

Switch on the chosen Heat Main Circulation System.

Heat Main Circ 0 Operat Mode: OFF Component
--

Heat Main Circ 1 Heating Circuit 1 Heating Circuit 2 DHW 1 HC1 OFF

In the menu item **component** you can assign any or all circuits to operate with the booster pump. The booster pump runs with any assigned pump.

15. Pellematic CMP

See also chapter **Pellematic** page 23

16. Pellematic settings

Pellematic	Pellematic
Boiler Temp : 127.5 °F	T Increase : 50.0 °F
Boiler T set: 46.4 °F	Min Boiler T: °F
Heat Main Circ	Max Boiler T: 203.0 °F
settings menu	Pump ON Temp: 68.0 °F
	further menu

Boiler increase temperature

This calculates the boiler set point taking into account the highest user calling at the time. Ensures there is sufficient temperature difference between boiler and user - heating circuit/DHW for effective heat exchange.

Example:

The set hot water temperature amounts to 140°F, the increase temperature of the hot water amounts to 9°F. If the boiler increase temperature amounts to 18°F, it results that the boiler temperature set point is 167°F. (DHW temp. + DHW increase temp. + boiler increase temp.)

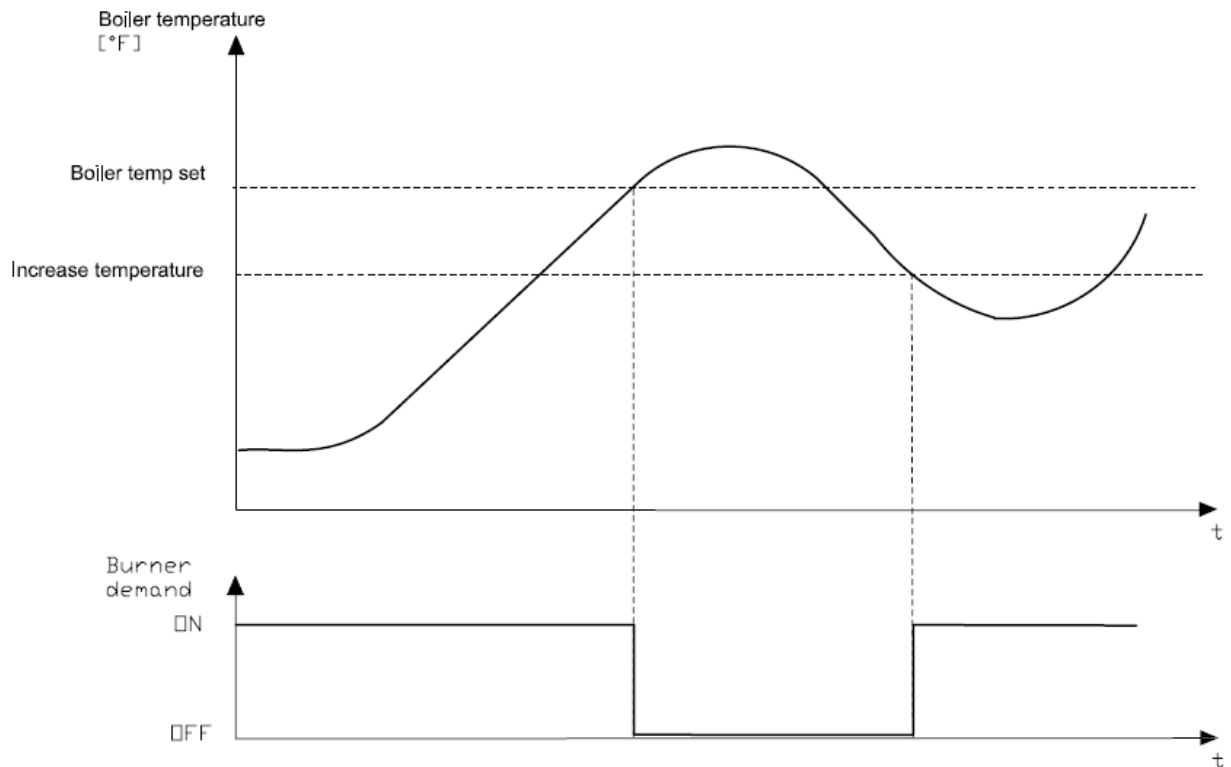

Minimum boiler temperature

The minimum boiler temperature protects boiler from internal corrosion and ensures optimum combustion conditions. Limited to 140°F when no accumulator is installed.

Maximum boiler temperature

Cools the boiler, by switching on all pumps and opening mixers, when the maximum boiler temperature is reached. This procedure stops, if either the boiler temperature falls below the maximum boiler temperature minus the set boiler increase temperature.

(boiler temperature max. 203°F minus boiler increase temp. 12.6°F = 190.4°F)

Pump on temperature

They cannot be switched on, when the boiler temperature is below the set switch on temperature.

NOTICE	
This function is for boiler corrosion protection and is not used when an accumulator is installed.	

Pump temperature min for systems without accumulator tank is 140°F, protects boiler from internal corrosion and ensures optimum combustion conditions.

16.1 Frost protection

Pellematic	
Frost Protection	
Temp Limit :	39.2 °F
Rest Time :	60min
Running Time:	5min
further	menu

Temperature limit:

The frost protection becomes active, if the outside temperature falls below the set temperature (default 39°F). When the outside temperature falls below, the mixers are opened and the system is flushed by the pumps every 55 minutes for 5 minutes.

If any internal sensor falls below 46°F, then the boiler is called. This limit is adjustable from -4 to 39°F.

	 CAUTION
This function doesn't protect against frost damage!	

Frost protection rest time and running time:

Within this interval the pumps were not headed for other reasons, then these are switched on for one period (the freeze protection - running time) and the mixers are opened.

16.2 Cascade function

Pellematic	
No of Boiler:	1
Hyst 1 :	35.6 °F
Hyst 2 :	41.0 °F
Hyst 3 :	37.4 °F
further	menu

Pellematic	
Boiler Duty:	50hr
OFF Temp :	68.0 °F
further	menu

Number of boilers:

If the Pellematic CMP is 1 or more, the number of boilers is adapted automatically.

If the number of Pellematic CMP is 0 you can adapt it here.

If the number of Pellematic CMP is between 1 and 4, the number can't be adapted here.

The number of Pellematic CMP you find in **Learning Periphery**, page 28.

Hysteresis 1, 2 and 3:

Avoid the clocking of the boiler by setting ON and OFF temperatures.

Boiler duty: It always starts with the lead boiler. Each boiler runs for the same period of time. But the sequence of operation changes to ensure equal running time for each boiler.

The boiler duty is the operating time of each boiler.

NOTICE	
If the setting of the boiler duty is 0, then always boiler number 1 starts.	

Off temperature:

When the outside temperature is higher than the off temperature, **no** requirement is issued to these

- boilers: Boiler 2..... cascade with two boilers
- Boiler 2 and 3.... cascade with three boilers
- Boiler 3 and 4..... cascade with four boilers

Pellematic	
No of Boiler:	2
Hyst 1 :	35.6 °F
Hyst 2 :	41.0 °F
Hyst 3 :	37.4 °F
further	menu

Pellematic	
Boiler Duty:	50hr
OFF Temp :	68.0 °F
Reserv Boiler:	OFF
Delay Time	menu

To get to the menu points **Reserve Boiler** and **Delay Time**, the number of boilers has to be at least 2.

Reserve Boiler:

It is possible to connect a reserve boiler which is excluded from the duty cycle.
It is only used for the coverage of maximum demand of energy.



Delay time:

It ensures that number 2 and subsequent boilers start in sequence and only when the load demands.

Description of the function of the four possibilities of cascades

- Boiler 1.....I/O BOX 1 burner contact
- Boiler 2.....I/O BOX 1 reserve output
- Boiler 3.....I/O BOX 2 burner contact
- Boiler 4.....I/O BOX 2 reserve output

NOTICE	
Install an additional relay at the reserve output. See the manual: “Additional relay for plants of several boilers Pelletronic Plus number of the part E1259“	

	 CAUTION
Only 1 boiler sensor is needed in the cascade system. This must be positioned where a common flow temperature can be measured and connected to I/O box 1	

2 Cascade without accumulator

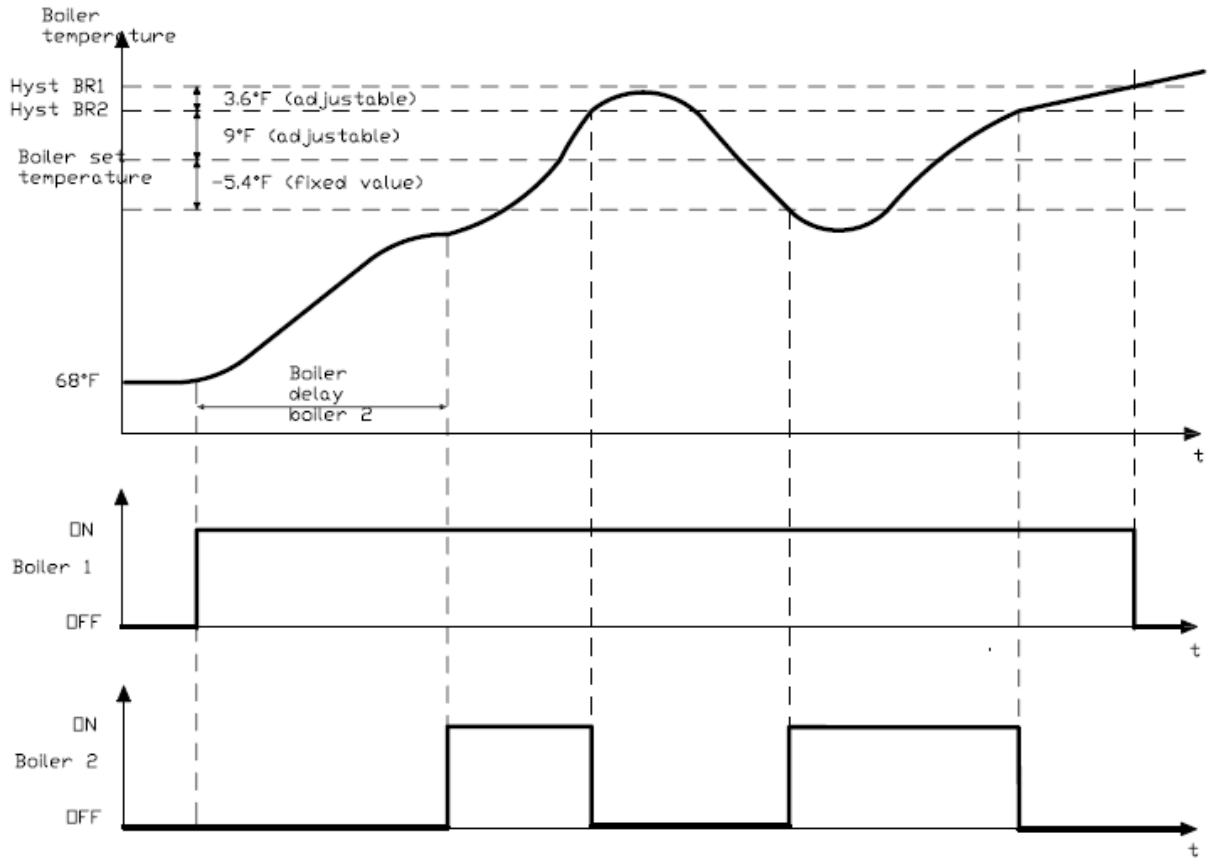

2 Cascade with accumulator

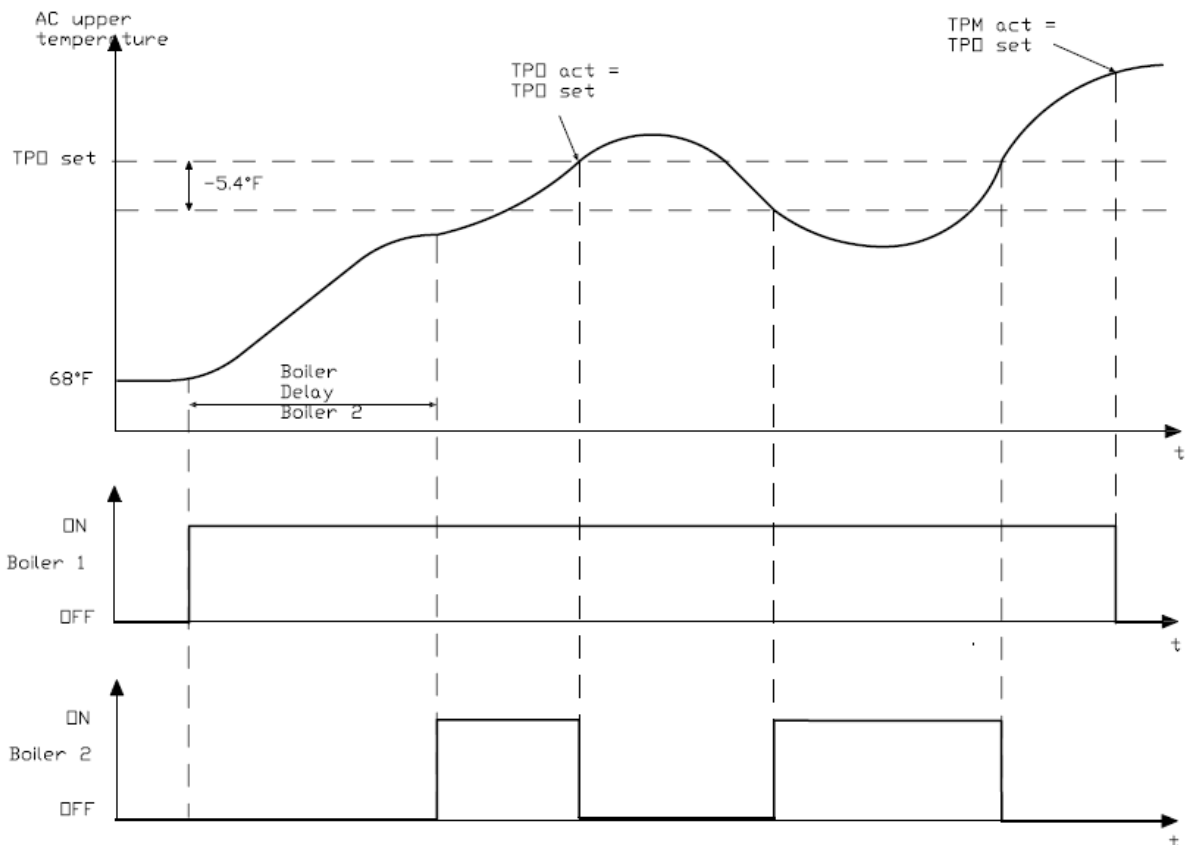

3 Cascade without accumulator

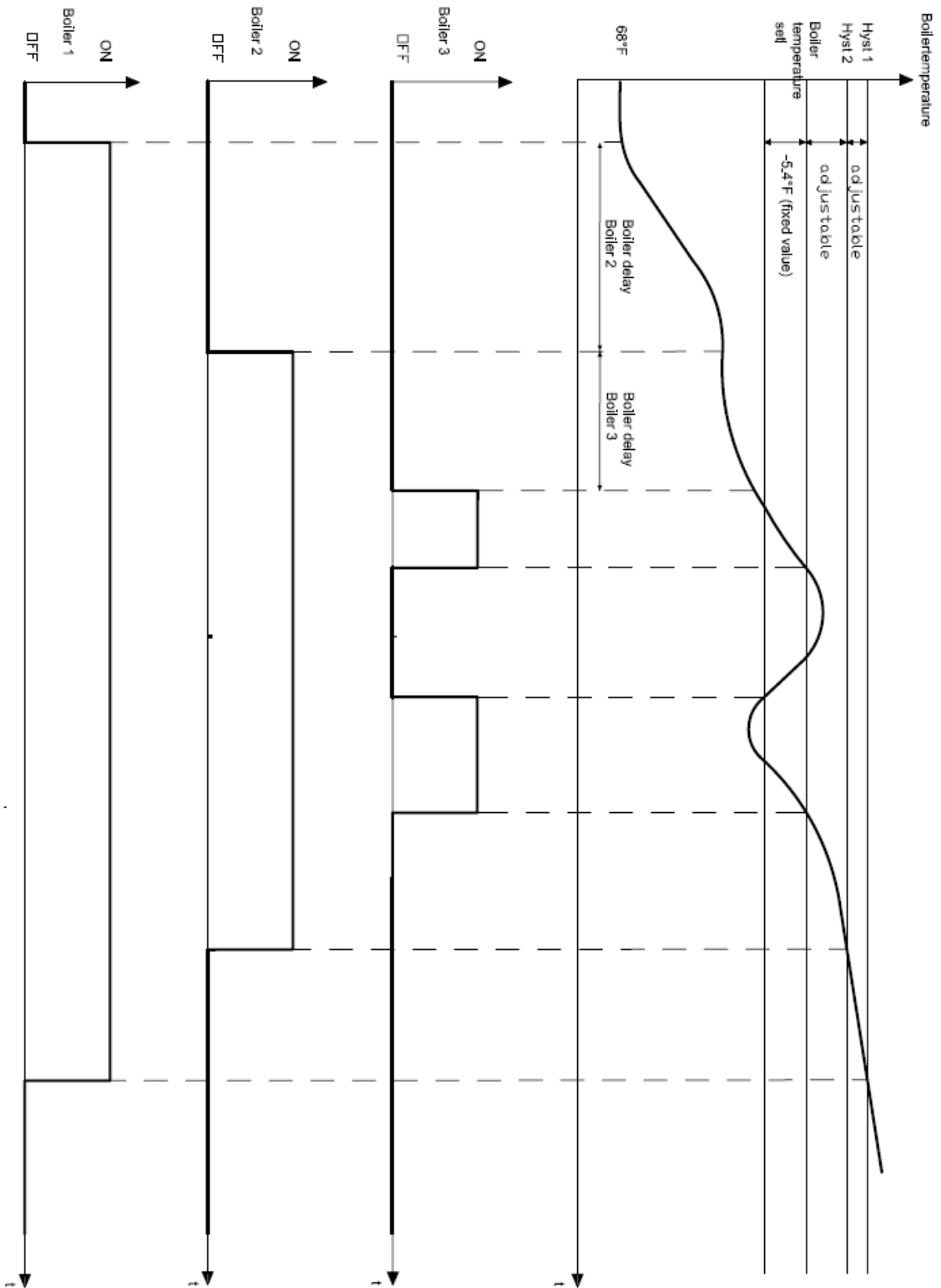

3 Cascade with accumulator

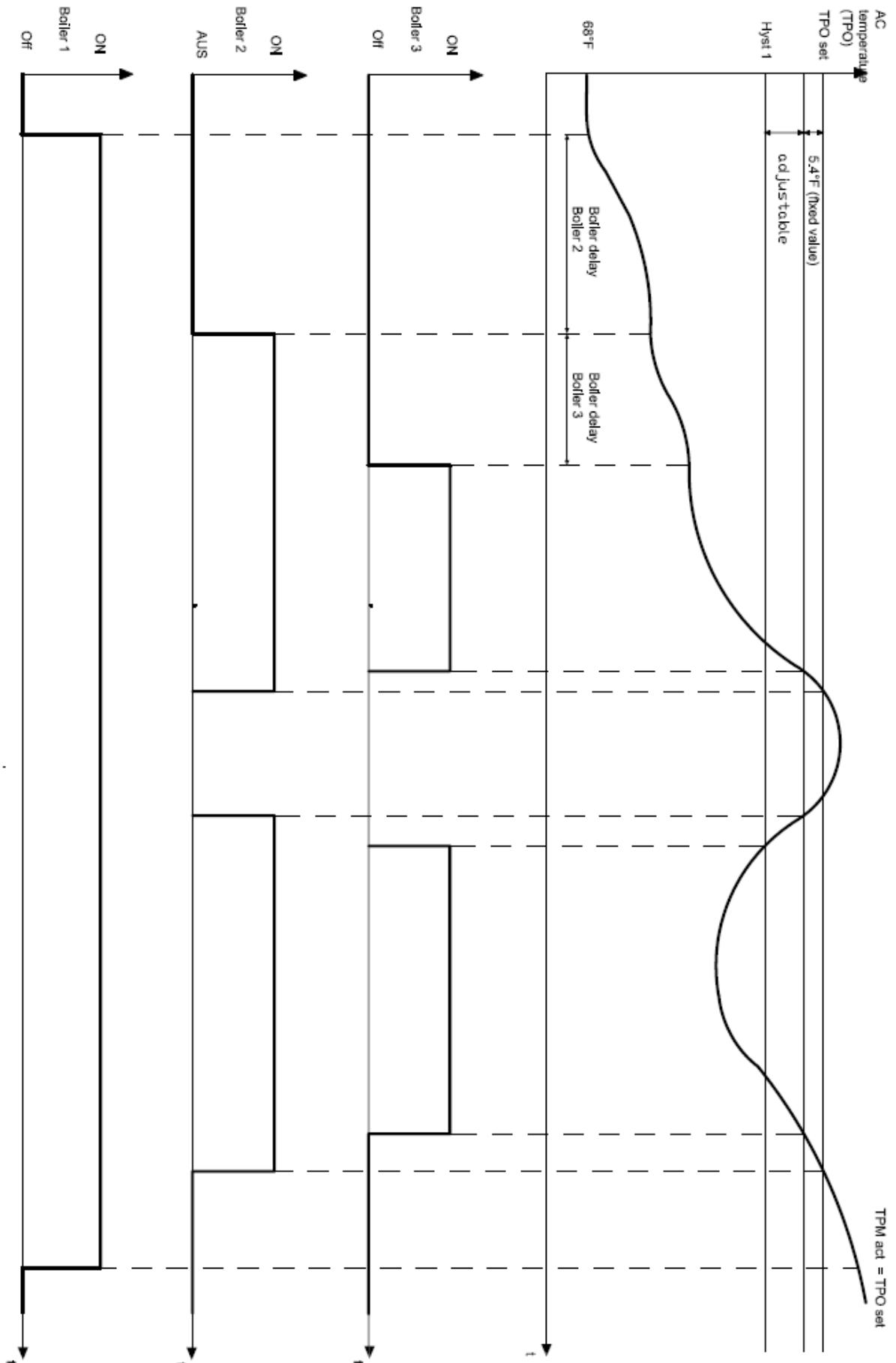

4 Cascade without accumulator

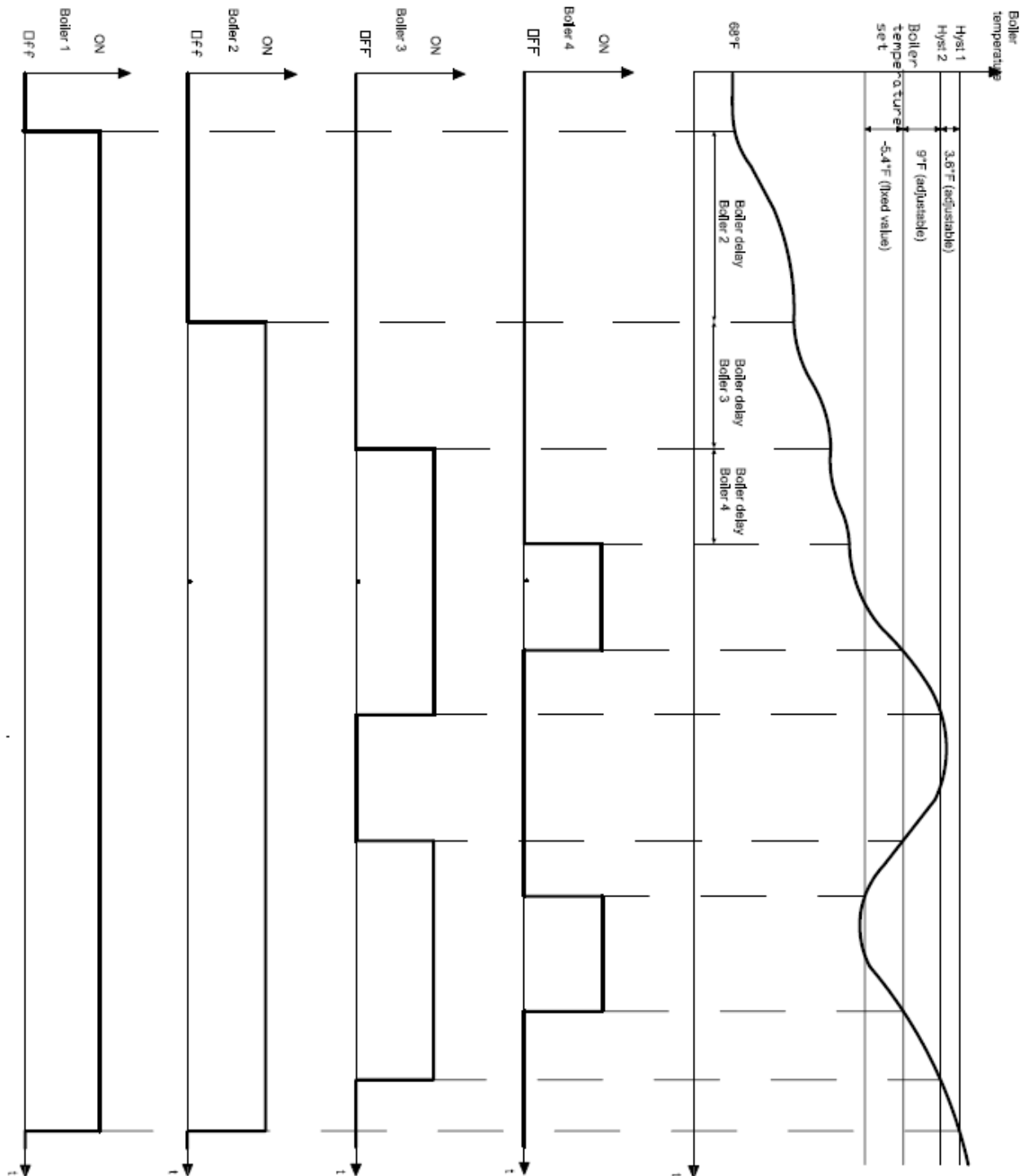

4 Cascade with accumulator

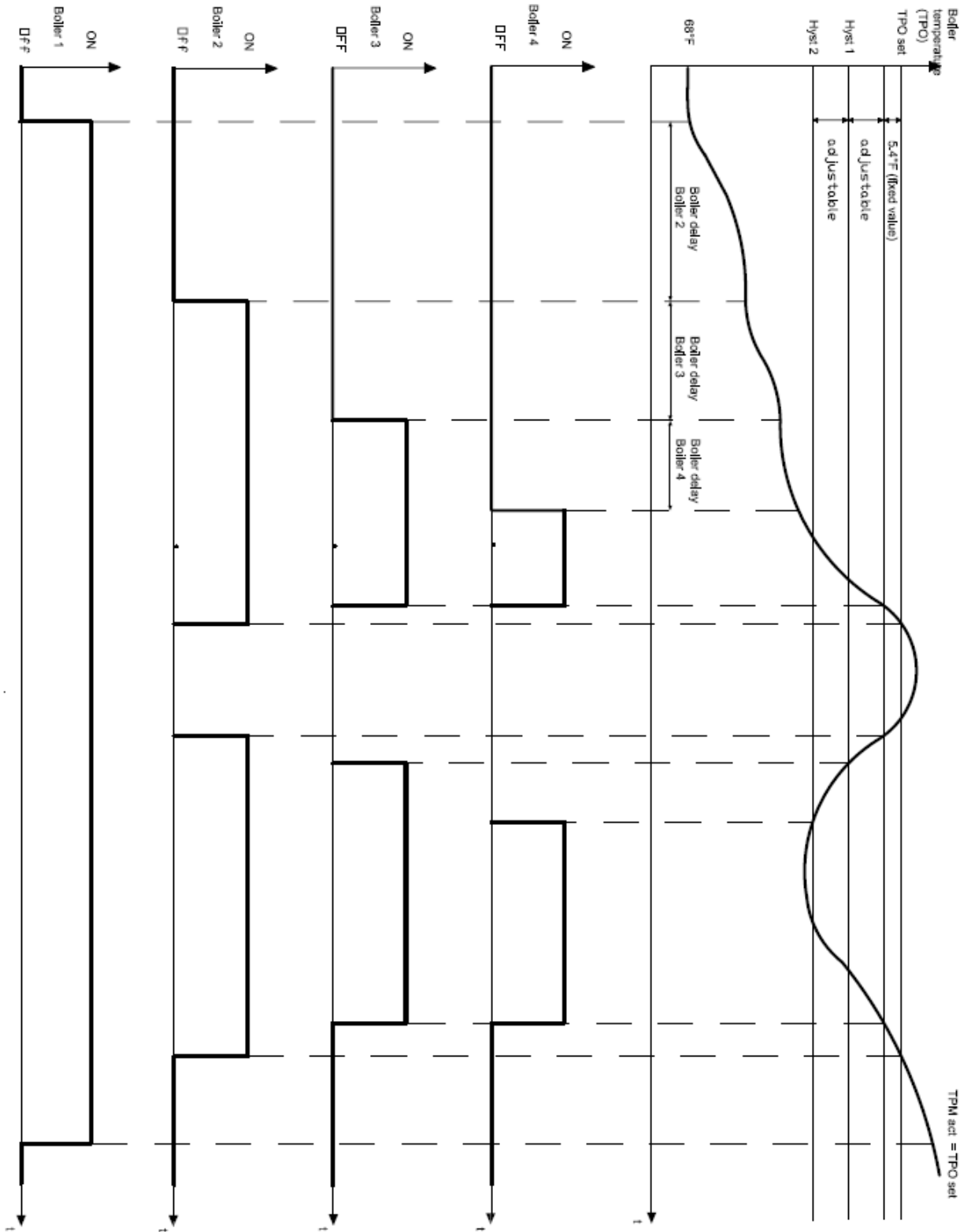

17. General menu

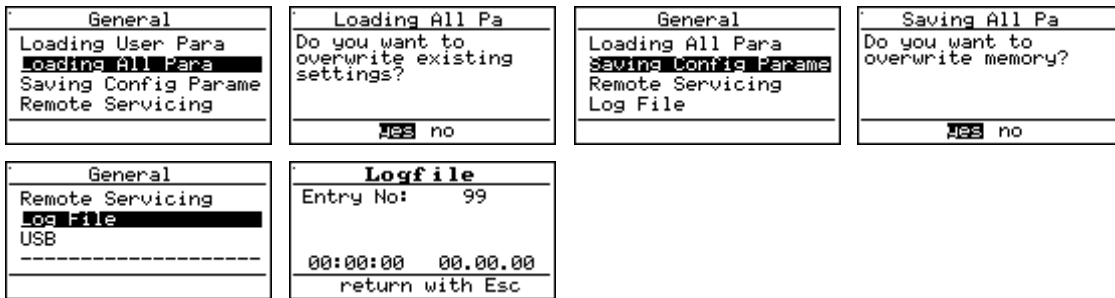

Loading all parameters

All previously saved parameters may be loaded from the internal memory.

Saving all parameters

All parameters are saved.

Log-File

All attempted and successful code inputs are logged.

Logs access to code level

18. USB

There are 4 USB functions, when a USB Stick is connected to the Pelletronic:

- **Save Settings:** saves all parameters prior to updating software. Data is saved in a named file.



- **Load Settings:** loads the saved settings after the software update.

Select the right file by moving the arrows right or left



- **Save all data:** logs all heating controller activity, excludes mixer activity

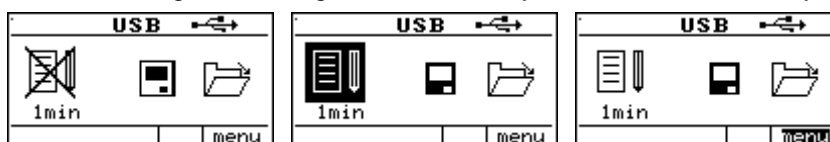

- **Software update**

You can load software from a USB stick.

Preconditions:

- The controller must have a USB port.
- Only version 2.18 or higher may be used.

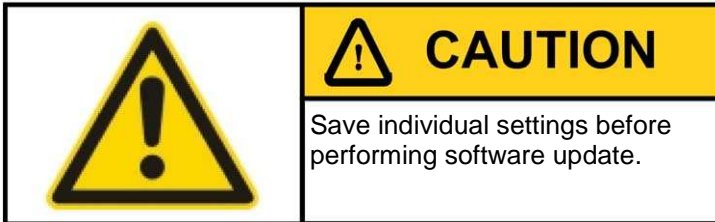

Operational sequence:

1. Disconnect the heating controller from the power supply.
2. Remove controller from the fastener, the USB port is on the underside of the controller pc board
3. Plug in the USB stick.
4. Reconnect the heating controller to the power supply. The heating controller starts automatically.
5. There are 2 options:
 Stop the process with **Esc** OR
 confirm the update with **Enter**.
 After confirming with **Enter** the software update runs automatically.



6. When the update is complete, the display shows:
 "Program download complete"
7. Unplug the USB stick and restart device
 Disconnect the USB-Stick.
 Refit and restart the heating controller.

H. Diagram of the electrical connection

Pelletronic Plus I/O – Box and Pellematic

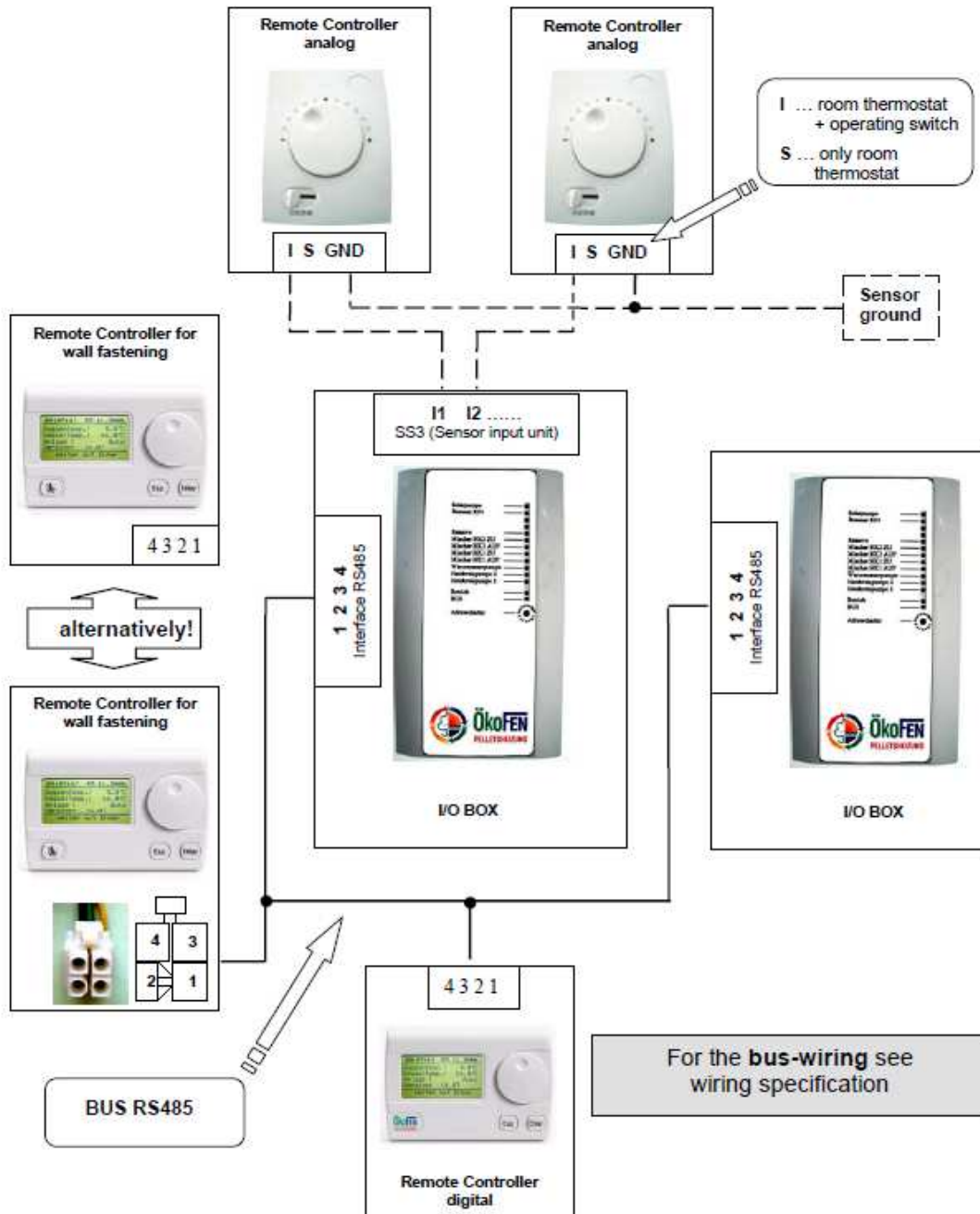

Connecting diagram I/O - BOX

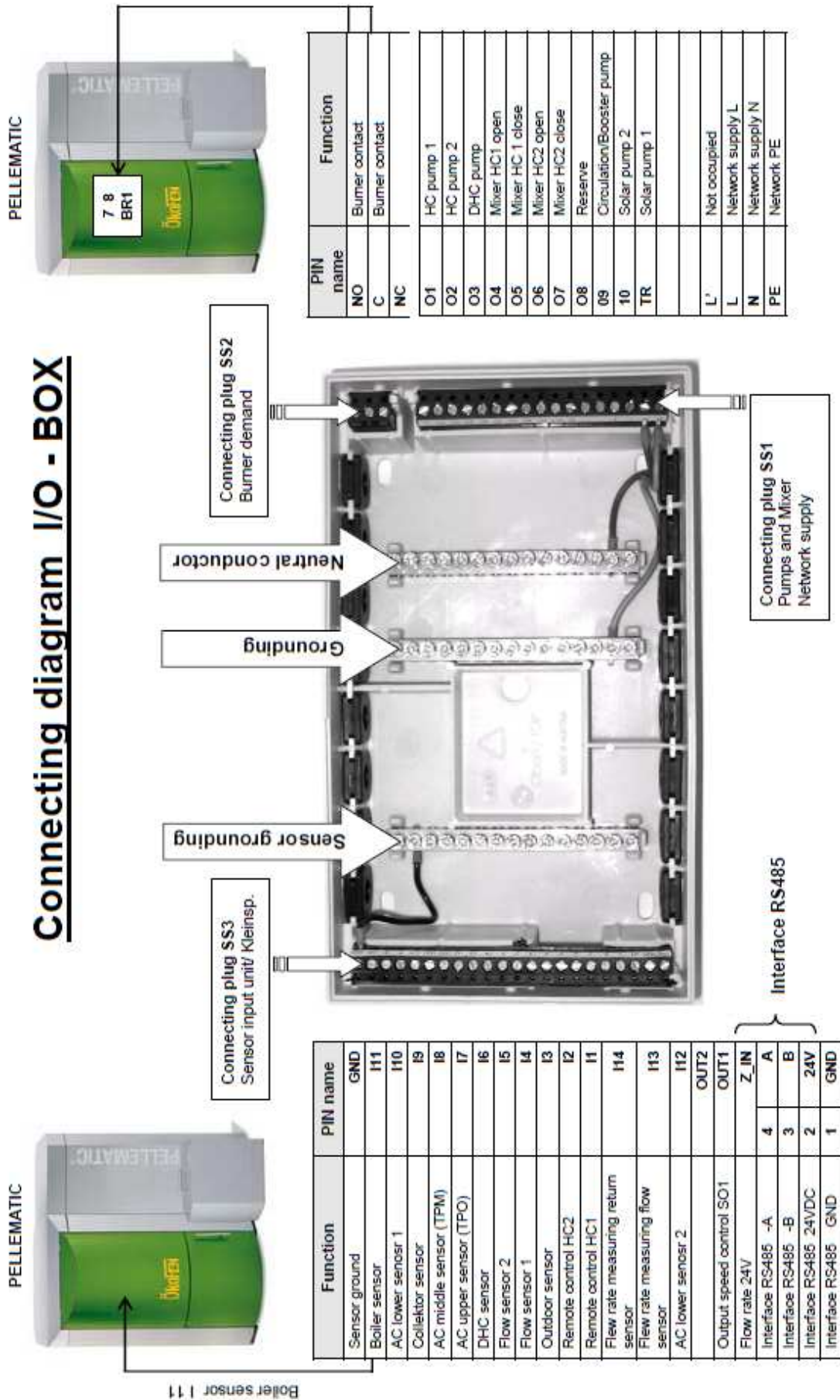



Cable specification

Output Units see the Connecting diagram at the front side				
Function	Pin name I/O BOX	Type of cable	Width	Max
HC pump 1	O1	YML-J	3x0.75	2A
HC pump 2	O2	YML-J	3x0.75	2A
DHC pump	O3	YML-J	3x0.75	2A
Mixer HC1 open	O4	YML-J	3x0.75	2A
Mixer HC1 close	O5	YML-J	3x0.75	2A
Mixer HC2 open	O6	YML-J	3x0.75	2A
Mixer HC2 close	O7	YML-J	3x0.75	2A
Reserve	O8	YML-J	3x0.75	2A
Circulation/booster pump	O9	YML-J	3x0.75	2A
Solar pump 2	O10	YML-J	3x0.75	2A
Solar pump 1	TR	YML-J	3x0.75	2A
Burner contact	C / NO	YML	2x0.75	x
Bus cable RS485	A / B / 24V / GND	LS-YYCVY-0Z	4x0.75	x
Output speed control SO1	OUT1	YML	2x0.75	x
				max pro I/O BOX 6,5A
Input Units see the Connecting diagram at the front side				
Function	Pin name I/O BOX	Type of cable	Width	Type of sensor
Remote control HC 2	I2	LS-YYCVY-0Z	4x0.75	x
Remote control HC 1	I1	LS-YYCVY-0Z	4x0.75	x
Outdoor sensor	I3	YML	2x0.75	KTY 2k
Flow sensor HC1	I4	YML	2x0.75	KTY 2k
Flow sensor HC2	I5	YML	2x0.75	KTY 2k
DHC sensor	I6	YML	2x0.75	KTY 2k
AC upper sensor	I7	YML	2x0.75	KTY 2k
AC middle sensor	I8	YML	2x0.75	KTY 2k
Collector sensor	I9	YML	2x0.75	PT1000
AC lower sensor 1	I10	YML	2x0.75	KTY 2k
Boiler sensor	I11	YML	2x0.75	KTY 2k
AC lower sensor 2	I12	YML	2x0.75	KTY 2k
Flew rate measuring flow	I13	YML	2x0.75	KTY 2k
Flew rate measuring return	I14	YML	2x0.75	KTY 2k
Flow rate 24V	Z_IN	YML	2x0.75	x
Network supply	L	YML-J	3x1	x

Wiring specification for Mikronetwork with 1, 2 or more heating controller

Heating controller 1 (HControl1) supplies the boiler control panel (BControl) & with max. 2 digital remote controllers (DRControl)

1. The order of the apparatuses at the bus-wiring is equally, but the numbers of HControl 1 and the BControl have to be used consistently and it is not allowed to use a number 2 times.
2. The numbers of the HControl1 are independent of the numbers of the DRControl
3. max. 16 Bus members
4. max. Bus-cable length: 800m (only by keeping the conditions)
5. die max. Bus-cable length depends from:
6. Topology – A max. Bus cable length is only possible with a direct point-to-point topology. With a star-topology (as shown in the example) is the full length impossible.
7. A screened cable (preferred twisted-pair) has to be used with long lines or if parallel are other lines displaced.
8. A proper Bus-connection-resistance – It is always in the boiler, but within long lines or problems of communication has to be used additionally at the last Bus-member a 120 Ohm resistance (0,5W). It has to be clammed between the A & B line.

	 CAUTION
	<p>The +24 V supply of the heating controller 2 mustn't be connected with the + 24 V supply of the heating controller 1.</p>

1 HControl can supply max. 3 BControls. In case of malfunction or disconnecting of 1 heating circuit, otherwise another HControl would have to overtake the supply.

This would cause a shutdown of all BControls.

The HControls are protected through a self resetting fuse. All HControls and BControls are protected against short circuit.

Wiring diagram for 1 heating controller

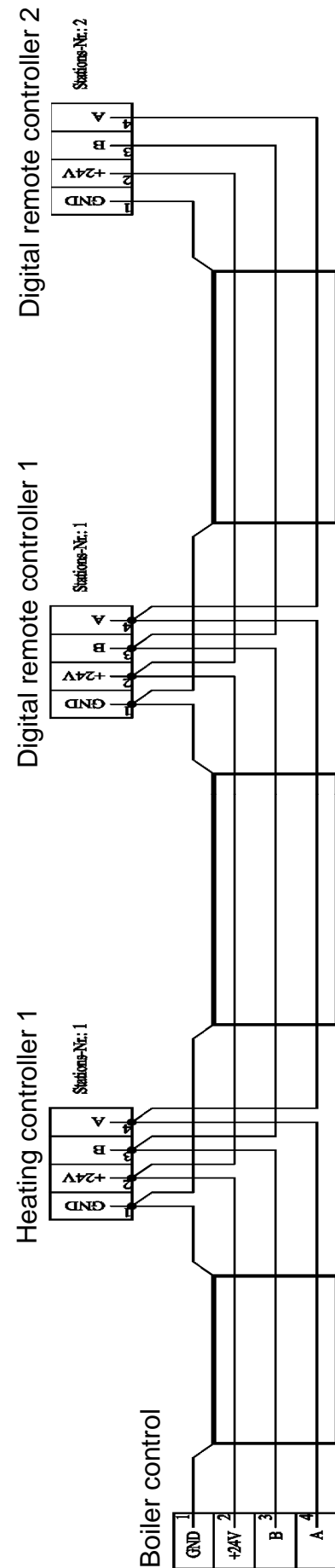

Wiring diagram for 2 or more heating controllers

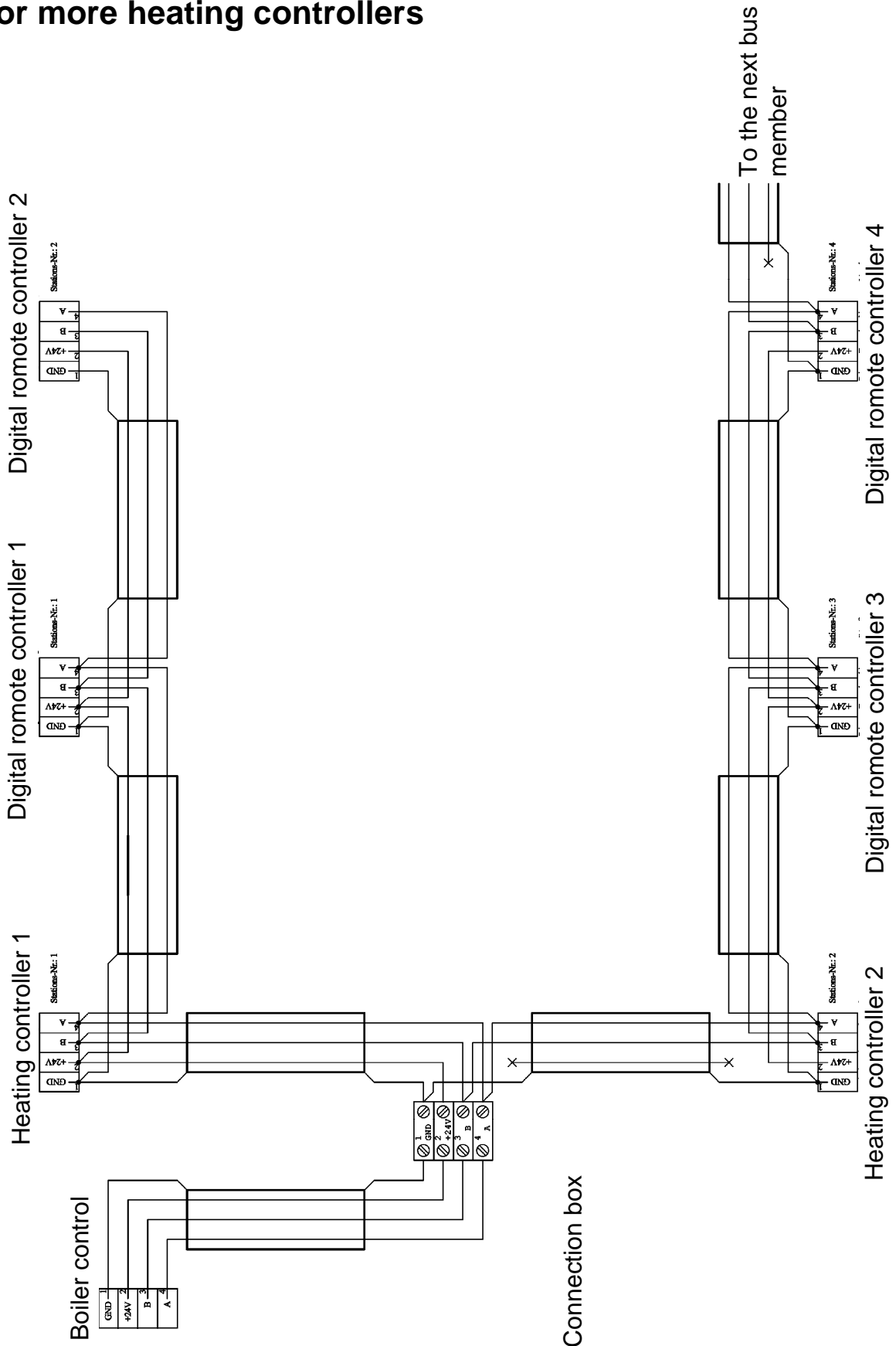

I. Terms of guarantee

For boiler assembly and associated parts that become demonstrably unusable due to faulty materials or production, the following terms of guarantee apply as from the date of start-up:

- Boiler 15.000 op. hours*/ max. 5 years
- Timber container incl. flue system and fixed parts of the system max. 5 years
- Multi express storage tan max. 5 years
- Solar collectors max. 10 years
- Bearings, chain pinions, chains and all moving parts 6.000 op. hours /max. 2 years
- Motorised gear boxes and pumps 6.000 op. hours /max. 2 years
- Electronic control, measuring, switching and adjustment devices 6.000 op. hours /max. 2 years
- Burner plate and fire tube 6.000 op. hours /max. 2 years

* Operating hours according to the operating time of the boiler.

Warranty- and guarantee claims can only be occupied, when from Maine Eco Pellet Heating LLC delivered goods are used under from Maine Eco Pellet Heating LLC predetermined, foreseen operation and normal use.

Manufacturer:

Maine Eco Pellet Heating LLC

8 Airport Road
Bethel, Maine 04217

USA

office@me-pelletheating.com

www.meco-pelletheating.com